

# N450 SERIES THERMOSTATIC STEAM TRAPS

Pressures to 450 PSIG (31 barg)  
Temperatures to 600°F (316°C)

**Compact** — Easy to Install.

**Inexpensive** — Low initial cost.

**Improved Energy Savings** — High efficiency—maximum elimination of air and non-condensibles.

**Temperature Sensitive Actuators** — One moving part. Stainless Steel, fail open, welded actuator for maximum corrosion, thermal and hydraulic shock resistance.

**Hardened Stainless Steel Valve and Seat** — Long life. Lapped as a matched set for water tight seal.

**Easily Maintained** — Can be inspected and serviced without breaking pipe connections.

**Freeze Proof** — Self draining when installed vertically.

**For Superheated Steam Applications** — Because the trap closes at saturated steam temperature, superheated steam cannot reach trap.

**Air Vent** — Efficient steam service air vent when equipped with ISO filled Actuator and installed in air vent location.

**Guaranteed** — Guaranteed against defects in materials or workmanship for 3 years.

**Positive Shutoff and Long Life** — Integral Stainless Steel Strainer helps prevent debris depositing on valve and seat.

## APPLICATIONS

- Unit Heaters
- Air Vents
- Steam Tracing
- Drip Legs
- Platen Presses
- Plating Tanks
- Sterilizers
- Tire Presses
- Cooking Equipment
- Laundry Equipment
- Other Process Equipment

## OPTIONS *See page 9*

- SK - Skirted Seat\*
- SLR - SLR Orifice
- ISO - ISO Filled Actuator\*
- S - Internal SS Strainer (std. on N451)
- ST - Sterilizer Trim
- SW - Socketweld

\*Not available on N451

## MODELS\*

- **N451-FO**—Low capacity, fail open only
- **N452**—Reduced capacity
- **N453**—Standard capacity
- **N454**—High capacity

\*Add (-FC) for fail closed or (-FO) for fail open to end of model number

Canadian Registration # OE0591.9

## OPERATION

Thermal actuator is filled at its free length with a liquid having a lower boiling point than water. On start-up, valve is normally open. When steam enters trap, thermal actuator fill vaporizes to a pressure higher than line pressure. This forces valve into seat orifice to prevent any further flow. As condensate collects, it takes heat from thermal actuator, lowering internal

pressure.

Line pressure will then compress thermal actuator to open valve and discharge condensate. Valve opening automatically adjusts to load conditions from minimum on very light loads to full lift at maximum load. Restricted orifice in the N451 seat (small opening at bottom of valve seat) prevents trap from discharging continuously on light loads such as are encountered on tracer lines.

# N450 SERIES THERMOSTATIC STEAM TRAPS

## SPECIFICATIONS

Steam trap shall be of balanced pressure design with stainless steel welded actuator capable of discharging condensate within 10°F of saturated temperature. Where greater sensitivity is required, SLR orifice and Sterilizer trim will be available to allow condensate evacuation at or near saturated temperatures. Where subcooling of condensate is desired alternate thermostatic actuator will be available to allow condensate evacuation at or near 40°F below saturated temperatures. Thermostatic actuator shall employ a conical valve lapped in matched sets with the seat ring assuring tight shut off. A minimum of three orifice sizes shall be available allowing for custom capacity sizing. Trap shall be forged carbon steel bodied suitable for pressures through 450 psig and available in 1/2" and 3/4" NPT or socket weld.

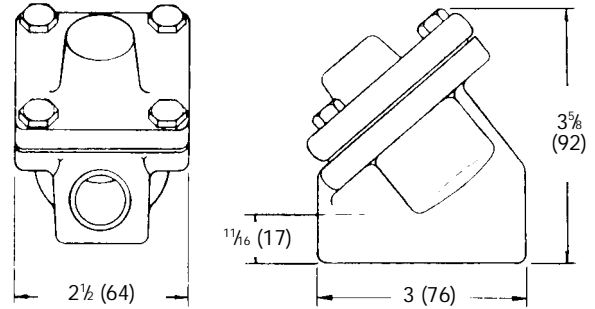

**WEIGHT: 3 LBS. (1.4 KG)**

Connections:  
1/2" or 3/4" NPT or socketweld

### MAXIMUM OPERATING CONDITIONS

PMO: Max. Operating Pressure† 450 psig (31 barg)  
TMO: Max. Operating Temperature 600°F (316°C)

PMA: Max. Allowable Pressure 450 psig (31 barg)  
TMA: Max. Allowable Temperature 750°F (399°C)

† Consult factory for pressures greater than 300 psi.

### MATERIALS OF CONSTRUCTION

Body .....ASTM A105 Forged Steel  
Cover .....ASTM A351 Grade CF8 (304)  
Cover Gasket .....304 SS Spiral Wound w/Graphite Fill  
Actuator .....Welded Stainless Steel  
Strainer .....033 Perf. 304 Stainless Steel  
Valve & Seat .....Hardened 416 Stainless Steel

Maximum Capacity—lbs/hr 10°F Below Saturation (Kg/hr 5°C Below Saturation)														
Trap	Orifice Inch (mm)	Differential PSIG (barg)												
		5 (0.34)	10 (0.7)	20 (1.4)	50 (3.4)	100 (6.7)	125 (8.4)	150 (10.1)	200 (13.4)	250 (16.8)	300* (20.1)	350* (24.1)	400* (27.6)	450* (31.0)
N451	5/64 (2)	84 (38)	119 (54)	168 (76)	265 (120)	348 (158)	375 (170)	398 (181)	439 (199)	472 (214)	502 (228)	529 (240)	553 (251)	575 (261)
N452	1/8 (3)	216 (98)	265 (120)	375 (170)	592 (269)	778 (354)	838 (381)	890 (405)	980 (445)	1055 (480)	1121 (510)	1180 (536)	1235 (561)	1284 (584)
N453	1/4 (6)	550 (249)	825 (374)	1210 (549)	1975 (896)	2825 (1281)	3140 (1424)	3425 (1554)	3650 (1656)	3960 (1796)	4100 (1860)	4230 (1919)	4420 (2005)	4600 (2086)
N454	5/16 (8)	860 (390)	1220 (554)	1725 (783)	2725 (1237)	3575 (1623)	3850 (1748)	4090 (1857)	4505 (2045)	4850 (2202)	5155 (2340)	5425 (2463)	5675 (2576)	5900 (2679)

\* Nicholson recommends skirted seat above 300 PSIG (20.7 bar). Nicholson recommends ISO filled Actuator for superheated steam.