



CDH SANITARY THERMOSTATIC STEAM TRAPS

**Pressures To 100 PSIG (6.9 barg)
Temperatures to 338°F (170°C)**

APPLICATIONS

- CIP/SIP System Condensate Drainage
- Sterilization of Process Vessels
- Culinary Steam
- Humidifiers
- WFI System Sterilization
- Fermenter Sterilization

OPTIONS

- MP - Mechanical Polish to 10 μ in. (0.25 μ m) Ra
- EP - Electropolish
- SLR - SLR Orifice
- Tef-Steel, PTFE, Teflon®, E.P.D.M., and other gasket materials available

APPLICABLE CODES

- ASME BPE

Canadian Registration # 0E0591.9C

OPERATION

Thermal actuator is filled at its free length with a liquid having a lower boiling point than water. On start-up, valve is normally open to discharge air, non-condensibles and condensate. When steam enters trap, thermal actuator fill vaporizes to a pressure higher than line pressure. This forces

Universally Configurable—Horizontal connections from any direction on standard model; AI and AO models feature one multi-directional horizontal and one vertical connection.

Steepest Interior Surfaces—Designed to completely drain without puddling, even in significantly sloped lines.

Stainless Steel Body—Body Material is 316L Stainless Steel with 20 μ in. (0.5 μ m) Ra internal finish and 32 μ in. (0.75 μ m) Ra external finish. Available with mechanical polishing to 10 μ in. (0.25 μ m) Ra and/or electropolish.

Self centering Valve—Leak tight shut off. Assembly of actuator and valve to impingement plate allows the valve to self align with center of the orifice.

Temperature Sensitive Actuator—One moving part. 316L Stainless Steel, fail open, welded actuator for maximum corrosion, thermal and hydraulic shock resistance.

One Size Suits Most Services—Universal hygienic clamp fits both 1/2" and 3/4" piping.

Maintenance—Can be easily removed and disassembled for sterilization and/or repair.

Four Year Guarantee—Guaranteed for four years against defects in material or workmanship.

Inventory Standard Food Grade Gasket—White Viton food grade gasket offers superior performance for higher pressure steam applications.

Superior Air Handling—Best air handling capability provides for fast startup.

Unique SLR Orifice Option—Specify when immediate elimination of condensate and improved sensitivity is desired. An orifice on the valve allows for continuous discharge of condensate. Trap will nominally pass 50 lb/hr (22.7 kg/hr) of condensate at 50 psi (3.4 barg) within 0.5°C (1°F) of saturated temperature.

Bar Stock—Connection fittings are not welded onto inlet and outlet pieces.

MODELS

- CDH-AI-AO—Horizontal inlet and outlet
- CDH-AI—Horizontal inlet, vertical outlet
- CDH-AO—Vertical inlet, horizontal outlet

NOTE: Please specify if Material Test Reports (MTR) or Certificates of Conformance (COC) are required.

valve into seat orifice to prevent any further flow. As condensate collects, it takes heat from the actuator, lowering internal pressure. Line pressure will then compress thermal actuator to open valve and discharge condensate. Valve opening automatically adjusts to load conditions from minimum on very light loads to full lift at maximum load.

CDH SANITARY THERMOSTATIC STEAM TRAPS

SPECIFICATION

Steam trap shall be of balanced pressure design with 316L welded bellows capable of releasing condensate within 5°C (10°F) of saturated pressure. All other interior wetted components shall be of 316L stainless. It shall have interior body finish of at least 20 µ in. (0.5 µm) Ra and exterior body finish of at least 32 µ in. (0.75 µm) Ra. Trap shall utilize hygienic body clamp allowing disassembly for inspection or cleaning and be entirely self draining in horizontal or angle piping configuration. Trap end connections shall be standard hygienic clamp. Thermostatic actuator shall employ a conical valve lapped to the seat. Traps shall have SLR orifice where drainage at saturated temperatures is required. Traps shall be guaranteed against defects for four years.

MAXIMUM OPERATING CONDITIONS

PMO: Max. Operating Pressure	100 psig (6.9 barg)
TMO: Max. Operating Temperature	338°F (170°C)
PMA: Max. Allowable Pressure	150 psig (10.3 barg)
TMA: Max. Allowable Temperature	366°F (186°C)

MATERIALS OF CONSTRUCTION

Part #	Part Name	Material
1	Body – Inlet	A276 316L
2	Clamp	304
3	Gasket	Viton 3227
4	Body – Outlet	A276 316L
5	Actuator Nut	316L
6	Impingement Plate	316L
7	Actuator	316L SS
8	Valve	316L

CONNECTION

Sanitary Ferrule accommodates 1/2" and 3/4" service

BODY SURFACE FINISH:

Internal <20 µ in. (0.5 µm) Ra SFCI. External <32 µ in. (0.75 µm) Ra. Optional mechanical polishing to 10 µ in. (0.25 µm) Ra and/or electropolish SFC4

GASKET APPROVALS:

FDA, USDA, USP Class VI, 3A Sanitary Standard, NSF

SLR ORIFICE OPTION

Specify when immediate elimination of condensate and improved sensitivity is desired. An orifice on the valve allows for continuous discharge of condensate. Trap will nominally pass 50 lb/hr (22.7 kg/hr) of condensate at 50 psi (3.4 barg) within 0.5°C (1°F) of saturated temperature.

POLISHING PROCEDURE

All surface finishes are achieved without the use of additional buffing, compounds or grit.

Maximum Capacity—lbs/hr 10°F Below Saturation (Kg/hr 5°C Below Saturation)		Differential PSIG (bar)										
Trap	Orifice Inches	5	10	20	30	40	50	60	70	80	90	100
		(0.34)	(0.7)	(1.4)	(2.1)	(2.8)	(3.4)	(4.2)	(4.9)	(5.6)	(6.2)	(6.9)
CDH	1/4	550 (249)	825 (374)	1210 (549)	1495 (678)	1750 (794)	1975 (896)	2175 (987)	2350 (1066)	2525 (1145)	2650 (1202)	2825 (1281)

For Kg/Hr Multiply by .454

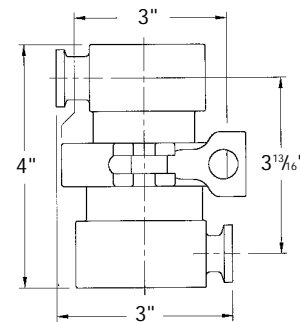

CDH-AI-AO – 3.9 LB.(1.8 kg)

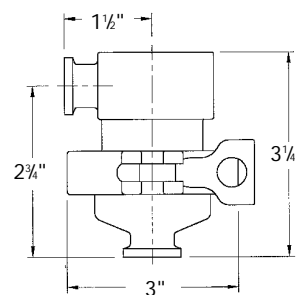

CDH-AI – 2.6 LB. (1.2 kg)

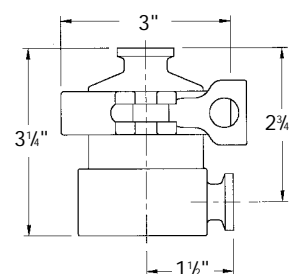

CDH-AO – 3.1 LB. (1.4 kg)

Connections:
1/2/3/4" Hygienic Clamp

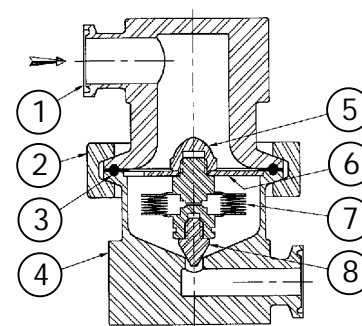

U.S. PATENT NO. 6,220,519