

## Parts List (Typical PAG Series Actuator)

PARTS		
NO.	DESCRIPTION	MATERIAL
1	End Cap Retaining Ring	Cataphoresis Coated Steel
2	Double Acting End Cap	Polyamide
3	End Cap O-Ring	NBR
4	Piston	Polyarilamide
5	Actuator Body	Polyamide
6	Washer	Polyamide 6
7	Shaft Retaining Ring	Stainless Steel
8	Position Indicator	Polyamide
9	Piston Guide	Polyacetal
10	Guide Ring	Polyacetal
11	Piston O-Ring	NBR
12	Upper Shaft O-Ring	NBR
13	Lower Shaft O-Ring	NBR
14	Spring Set	Cataphoresis Coated DIN-17223-C
15	Spring Return End Cap	Polyamide
16	Shaft	303 Stainless Steel
17	Pinion Gear	Aluminum Alloy

## Torque Air to Spring (Inch-Pounds)

MODEL	Spring Set	40 psi		60 psi		80 psi		100 psi		120 psi		Spring Torque	
		Start	End	Start	End	Start	End	Start	End	Start	End	Start	End
AP79PS	1	44	31	71	58	112	98	-	-	-	-	40	27
	2	33	12	59	40	100	81	140	120	-	-	58	38
	3	-	-	46	16	87	56	127	96	151	121	82	51
	4*	-	-	-	-	81	46	120	86	145	111	92	58
BP9PS	1	60	42	100	81	159	140	-	-	-	-	62	42
	2	37	10	77	50	136	109	196	168	-	-	93	65
	3	-	-	51	27	111	86	170	144	209	184	116	91
	4*	-	-	-	-	102	61	160	119	200	184	141	100
CP79PS	1	176	126	289	238	458	407	-	-	-	-	165	115
	2	-	-	228	157	397	325	566	494	-	-	248	175
	3	-	-	-	-	319	215	488	383	600	496	358	253
	4*	-	-	-	-	287	160	455	328	567	441	412	286
DP79PS	1	466	317	725	577	1113	965	-	-	-	-	371	222
	2	342	95	601	354	989	743	1378	1131	-	-	593	346
	3	-	-	453	132	841	519	1230	908	1489	1167	816	495
	4*	-	-	-	-	767	421	1156	810	1414	1068	914	568

\*Number of springs in standard unit

## Torque Air to Air (Inch-Pounds)

Model	Supply Pressure (psi)				
	40	60	80	100	120
AP79P	70	100	138	175	203
BP79P	103	142	202	261	300
CP79P	291	404	573	741	853
DP79P	688	947	1335	1724	1982

## Cycle Time (Seconds)

Model	Air to Air		Air to Spring	
	Open Port A	Closed Port B	Open Port A	Closed Port B
AP79P	0.10	0.10	0.15	0.15
BP79P	0.15	0.15	0.20	0.20
CP79P	0.25	0.25	0.30	0.30
DP79P	0.40	0.40	0.50	0.50

## Air Consumption (Cubic Inches)

Model	Air to Air		Air to Spring	
	Open Port A	Closed Port B	Open Port A	Closed Port B
AP79P	4.58	3.05	4.58	-
BP79P	9.15	6.10	9.15	-
CP79P	21.36	19.53	21.36	-
DP79P	48.82	42.71	48.82	-

## Weight (Pounds)

Model	Air to Air	Air to Spring
AP79P	0.73	1.04
BP79P	1.68	2.27
CP79P	3.11	4.74
DP79P	6.48	10.91

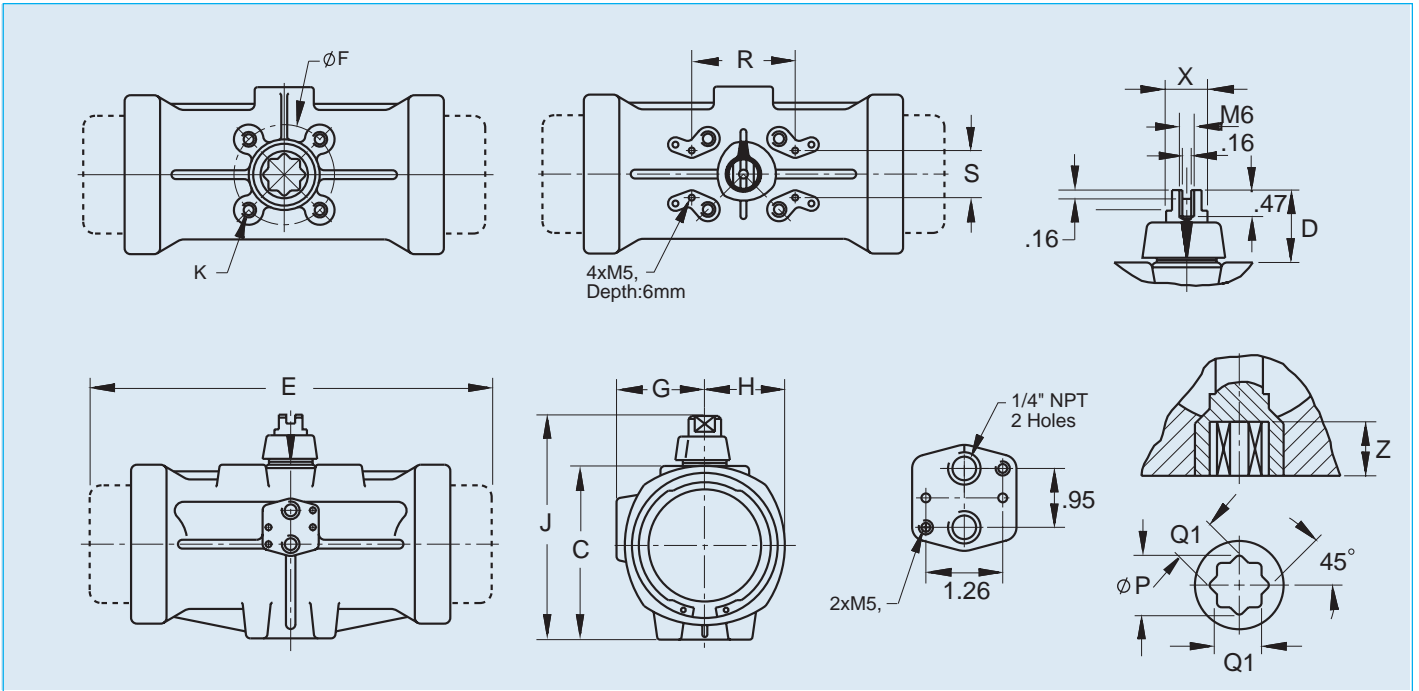

## Dimensions (IN.)

Model	C	D	E		F	G	H	J	K	P	Q1	R	S	X	Z
			A-A	AS											
AP79P	2.56	0.78	4.21	5.59	1.65	1.47	1.22	3.35	M5 x 7mm deep	.56	0.43	3.15	1.18	0.31	0.53
BP79P	3.15	1.18	4.92	6.10	1.96	1.73	1.42	4.33	M6 x 15mm deep	1.03	0.55	3.15	1.18	0.39	0.59
CP79P	3.86	1.18	7.16	9.06	2.76	2.09	1.93	5.04	M8 x 18mm deep	1.26	0.67	3.15	1.18	0.39	0.59
DP79P	5.20	1.18	9.17	11.97	2.76	2.56	2.36	6.38	M8 x 18mm deep	1.26	0.87	3.15	1.18	0.63	0.75