

TYPE C34 VALVE

TYPE C34 MAIN VALVE CAST IRON CONSTRUCTION Sizes 1" through 6"

The Spence Type C34 Main Valve is of normally closed, single-seat design. A minimum pressure drop of 10 PSI is required to operate the valve. Standard design features include packless construction, composite diaphragm, protected main spring and balanced composition disc.

This valve is intended for liquid service where load fluctuations are not violent. When controlled by one or more of the various types of Spence Pilots, this valve will accomplish most functions required of a regulator.

RATINGS (Maximum Inlet Conditions)

Valve Ends	Pressure	(Temperature)
------------	----------	---------------

- ANSI NPT Screwed200 PSIG(200°F)
- ANSI 125 Flanged.....165 PSIG(200°F)
- ANSI 250 Flanged.....200 PSIG(200°F)

RATED FLOW COEFFICIENTS (Cv)

VALVE SIZE	1	1 1/4	1 1/2	2	2 1/2	3	4	5	6
Cv	5.5	12.5	17.3	24	36	53	86	139	196

DIMENSIONS (inches) AND WEIGHTS (pounds)

SIZE	FACE TO FACE			OTHER DIMENSIONS						APPROX. WT.		
	ANSI NPT	ANSI 125	ANSI 250	B	C	D	E	F	G	ANSI NPT	ANSI 125	ANSI 250
1	5 ³ / ₈	—	—	6 ⁷ / ₈	3 ³ / ₈	7	1 ³ / ₈	6	10 ³ / ₈	19	—	—
1 1/4	6 ¹ / ₂	—	—	6 ⁷ / ₈	3 ⁷ / ₈	7	1 ³ / ₁₆	6 ⁵ / ₈	11 ¹ / ₄	24	—	—
1 1/2	7 ¹ / ₄	—	—	6 ⁷ / ₈	4 ¹ / ₄	7	1 ⁵ / ₁₆	6 ³ / ₈	11 ⁷ / ₈	29	—	—
2	7 ¹ / ₂	8 ¹ / ₂	9	9 ¹ / ₈	4 ¹ / ₂	7	2 ¹ / ₁₆	6 ¹ / ₂	12 ¹ / ₂	46	51	60
2 1/2	—	9 ³ / ₈	10	9 ¹ / ₈	5 ¹ / ₂	7 ³ / ₈	2 ³ / ₈	6 ⁷ / ₈	14 ¹ / ₂	—	65	74
3	—	10	10 ³ / ₄	11 ¹ / ₈	6	8 ³ / ₄	2 ³ / ₄	7 ¹ / ₄	15 ⁷ / ₈	—	94	111
4	—	11 ⁷ / ₈	12 ¹ / ₂	13 ¹ / ₂	6 ⁵ / ₈	9 ³ / ₈	3	7 ³ / ₄	17 ³ / ₄	—	148	172
5	—	13 ⁵ / ₈	14 ¹ / ₂	13 ¹ / ₂	7 ⁵ / ₈	10 ⁷ / ₈	3 ¹ / ₂	8 ⁵ / ₈	20 ¹ / ₄	—	194	226
6	—	15 ¹ / ₈	16	13 ¹ / ₂	9 ¹ / ₈	13 ¹ / ₈	4 ¹ / ₄	10 ⁵ / ₈	25 ¹ / ₈	—	280	325

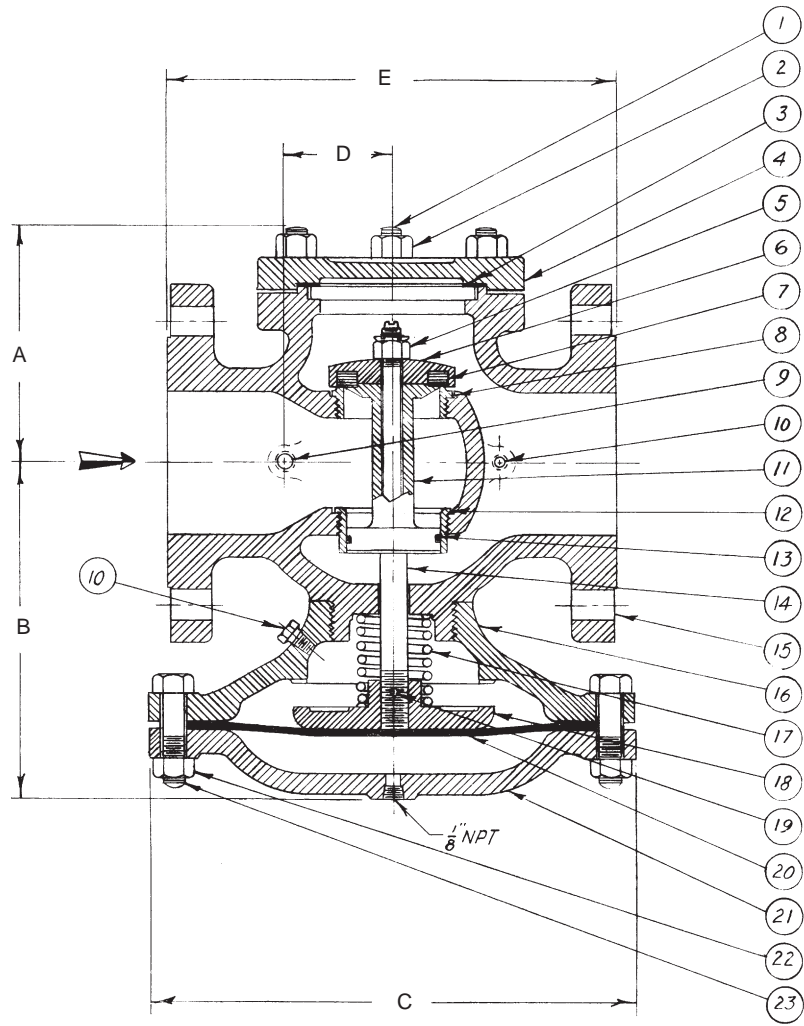

STANDARD C34 VALVE

STANDARD PARTS

ITEM NO.	PART NAME	MATERIAL	VALVE SIZE									
			1	1 1/4	1 1/2	2	2 1/2	3	4	5	6**	
1	Blind Flange Stud	Steel	04-05516-00	04-10118-00	40-05442-00	04-05443-00	04-10119-00	04-05448-00	04-10119-00	04-05448-00	04-05448-00	
2	Blind Flange Nut	Steel	05-02847-00	05-02851-00	05-02854-00	05-02856-00	05-02860-00	05-02862-00	05-02860-00	05-02862-00	05-02862-00	
3	Blind Flange Gasket*	Blugard	05-02381-00	05-02362-00	05-02382-00	05-02365-00	05-02366-00	05-02367-00	05-02369-00	05-02371-00	05-02372-00	
4	Blind Flange	Cast Iron	04-02171-00	04-02173-00	04-02176-00	04-02178-00	04-02180-00	04-02183-00	04-02186-00	04-02159-00	04-02161-00	
5	Stem Locknut*	Steel	05-03014-00	05-03015-00	05-03016-00	05-03016-00	05-03017-00	05-03017-00	05-03018-00	05-03019-00	05-03020-00	
6	Disc Holder	St. Steel†	04-09488-00	04-09489-00	04-09490-00	04-09491-00	04-09492-00	04-09493-00	04-09494-00	04-02531-00	04-02670-00	
7	Composition Disc*	Hycar	05-01715-00	05-01716-00	05-01716-00	05-01717-00	05-01718-00	05-01719-00	05-01721-00	05-01722-00	05-01724-00	
8	Seat Ring	St. Steel	04-04167-02	04-04169-02	04-04171-02	04-04172-02	04-04175-01	04-04177-01	04-04180-02	04-08681-01	04-08154-01	
9	Pipe Plug - 1/4 NPT	Steel	04-03772-00	04-03772-00	04-03772-00	04-03772-00	04-03772-00	04-03772-00	04-03772-00	04-03772-00	04-03772-00	
10	Pipe Plug 1/8 NPT	Steel	04-03769-00	04-03769-00	04-03769-00	04-03769-00	04-03769-00	04-03769-00	04-03769-00	04-03769-00	04-03769-00	
11	Balance Piston	St. Steel	04-09476-00	04-09477-00	04-09478-00	04-09479-00	04-09480-00	04-09481-00	—	—	—	
	Piston Assembly	St. Steel	—	—	—	—	—	—	22445	22525	22443	
12	Guide Ring	St. Steel	04-04397-01	04-04399-01	04-04401-01	04-04403-01	04-04405-00	04-04407-00	04-04411-01	04-08680-00	04-08153-00	
13	Piston O-Ring*	Nitrile	05-04015-00	05-04019-00	05-04023-00	05-04028-00	05-04033-00	05-04038-00	05-04045-00	05-04050-00	05-04051-00	
14	Stem	St. Steel	04-05323-00	04-05355-01	04-05320-01	04-05352-01	04-05349-00	04-05354-00	04-05350-00	04-05348-00	04-05351-00	
15	Body - ANSI NPT Scr.	Cast Iron	04-00625-00	04-00619-00	04-00628-00	04-00620-00	—	—	—	—	—	
	Body - ANSI 125 Flg.	Cast Iron	—	—	04-10686-00	04-00626-00	04-00682-00	04-00685-00	04-00850-00	04-00684-00	04-00853-01	
	Body - ANSI 250 Flg.	Cast Iron	—	—	—	04-00621-00	04-00680-00	04-00622-01	04-00681-00	04-00609-00	04-00683-01	
16	Base	Cast Iron	04-00545-00	04-00545-00	04-00545-00	04-00527-00	04-00527-00	04-00526-00	04-00525-00	04-00529-00	04-00528-01	
17	Spring*	Steel	05-04983-00	05-05001-00	05-05001-00	05-05138-00	05-05002-00	05-05021-01	05-02011-00	05-004698-00	05-05060-00	
18	Pressure Plate	Cast Iron	04-03606-00	04-03657-00	04-03699-00	04-03698-00	04-03705-00	04-03635-00	04-03672-00	04-02324-00	04-03689-00	
19	Pin	Steel	05-03244-00	05-03245-00	05-03245-00	05-03248-00	05-03248-00	05-03249-00	05-03254-00	05-03867-00	05-03255-00	
20	Diaphragm*	Hycar	05-01600-00	05-01600-00	05-01600-00	05-01601-00	05-01601-00	05-01602-00	05-01603-00	05-01603-00	05-01604-00	
21	Hood	Cast Iron	04-02630-00	04-02630-00	04-02630-00	04-02629-00	04-02629-00	04-02638-00	04-02634-00	04-02634-00	04-02633-00	
22	Diaphragm Nut	Steel	05-02874-00	05-02874-00	05-02874-00	05-02877-00	05-02877-00	05-02877-00	05-02881-00	05-02881-0	05-02881-00	
23	Diaphragm Bolt	Steel	05-04774-00	05-04774-00	05-04774-00	05-04780-00	05-04780-00	05-04780-00	05-04785-00	05-04785-00	05-04788-00	

REPAIR KITS

ITEM NO.	PART NAME	MATERIAL	VALVE SIZE									
			1	1 1/4	1 1/2	2	2 1/2	3	4	5	6	
	Repair Kit		08-09550-00	08-09551-00	08-09552-00	08-09553-00	08-09554-00	08-09555-00	08-09557-00	08-09558-00	08-09559-00	

When ordering parts, it is essential that the valve type, size, service and serial number be stated.

Select part by item number, but order by part number.

Specify complete part number when ordering.

NOTES:

- †5" and 6" Disc Holders are Cast Iron.
- *Parts furnished in Repair Kits
- **6" C34 Valves shipped after July, 1992 have top guided construction. The following parts are required:
 - 1 - Blind Flange 04-12150-00
 - 1 - Guide Bushing 04-12151-00
 - 2 - Stem Nuts 05-13842-00
 - 1 - Stem 04-12143-00

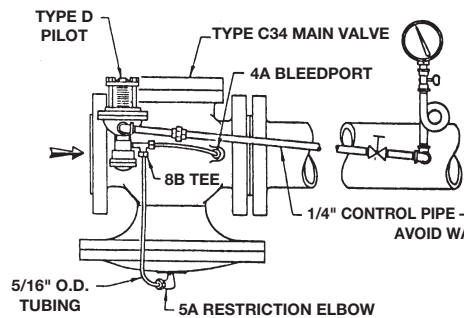

TYPE C34D PRESSURE REGULATOR

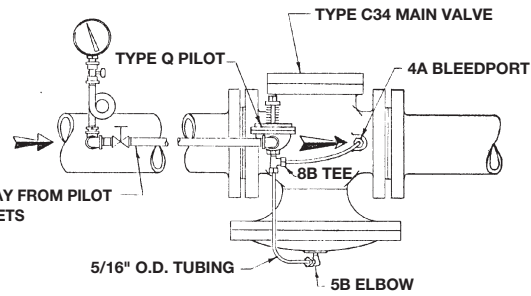

TYPE C34Q BACK PRESSURE REGULATOR

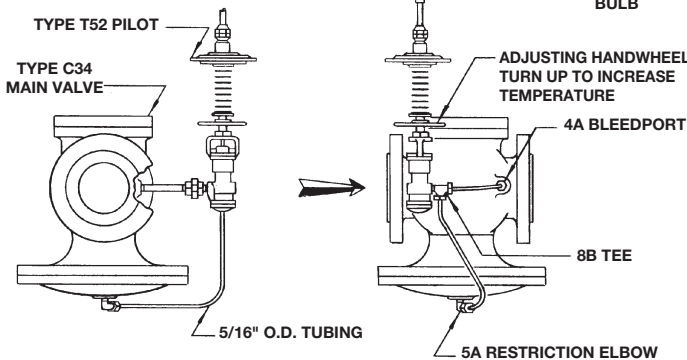

TYPE C34T52 TEMPERATURE REGULATOR

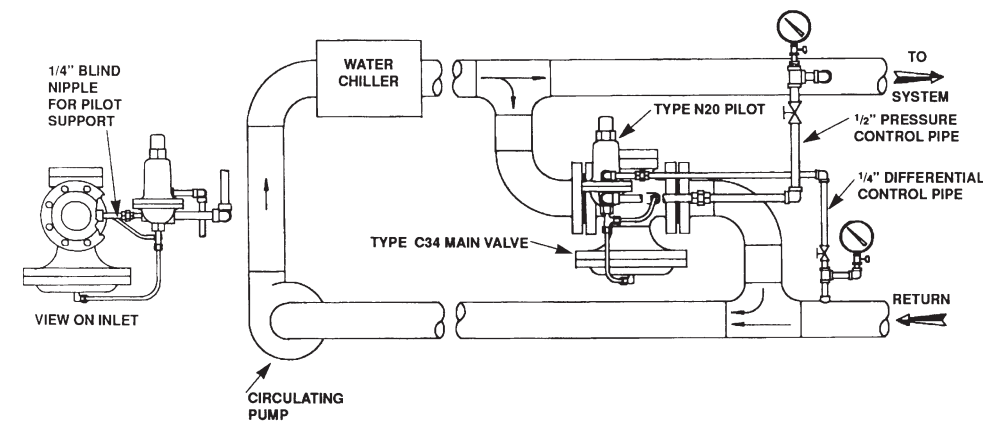

TYPE C34N20 DIFFERENTIAL BACK PRESSURE REGULATOR APPLIED TO A CHILLED WATER SYSTEM

MAINTENANCE INSTRUCTIONS

(Brackets refer to item number)

CAUTION: If valve is line mounted, be certain that inlet and outlet stop valves are closed and that internal pressure is relieved before dismantling.

DISMANTLING

1. Remove blind flange nuts (2) and lift off blind flange (4).
2. Connect an adjustable supply of air or water pressure to the hood (21) (See Fig. 1). Apply 20 to 30 PSIG to lock the stem in the full open position.
3. Apply a penetrating lubricant (such as WD40) to the stem locknut (5). Remove the locknut.
4. Lift out the disc holder (6), disc (7) and balance piston (11). Be careful when lifting the piston through the seat ring (8) so that the piston o-ring (13) is not damaged.
5. Release the hood loading pressure and remove the pressure loading equipment.
6. Remove the diaphragm nuts (22) while supporting the hood (21). Lower the hood to permit the diaphragm (20), stem/pressure plate (14 & 18) and main spring (17) to be withdrawn.
7. If the seat ring (8) requires replacement, remove it from the body. A special wrench is required.
8. If the guide ring (12) requires replacement, the valve must be removed from the line and the seat ring removed first. A special wrench is required to remove the guide ring. The guide ring is extracted through the valve inlet.

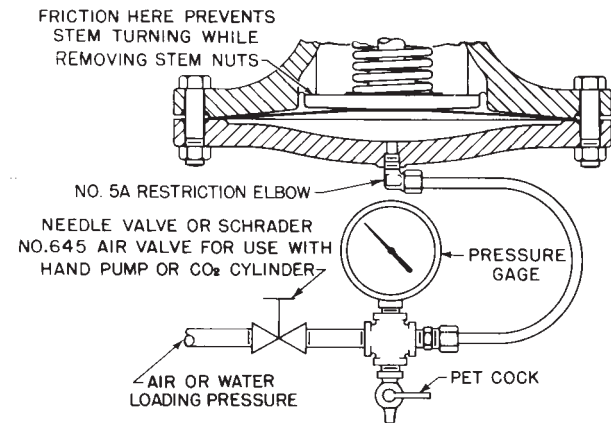

FIGURE 1

INSPECTION

1. Examine the seat ring (8), guide ring (13) and balance piston (11) for nicks, erosion or other damage from pipeline debris.
2. Inspect the disc (7) and piston o-ring (13) for wear and damage. Replace as required.
3. Examine the stem and inner body contours for accumulations of pipeline fines. Clean as required.

RING AND DISC REPLACEMENT

1. If seat ring or guide ring are being replaced, clean body threads of old sealing compound with a wire brush. Apply fresh sealing compound (Copaltite or equal) to the shoulder of the ring. Let stand until tacky before installing in valve body.
2. The composition disc (7) is reversible. Carefully pry it from the disc holder (6), flip and reinsert. Replace if both sides are worn.
3. Apply a silicone-base lubricant (Dow 55M or equal) to the piston o-ring (13) before carefully installing it into the groove of the balance piston (11).

STEM REPLACEMENT

1. Drive out pin (19) from pressure plate (18) and screw out old stem.
2. Secure balance piston (11), disc (7) and disc holder (6) to the new stem (14) with stem nut (5).
3. Insert this assembly into its normal position from the top of the valve. Screw on the pressure plate (18) (omit main spring (17)).
4. With the disc in contact with the seat, adjust the pressure plate until dimension K is obtained. This dimension is supplied with each replacement stem, cast into the pressure plate and appears in Fig. 2.
5. Push the pressure plate up until it stops and remove stem nut. Do not allow stem to turn relative to the pressure plate. Lift out disc and balance piston.
6. Remove stem and pressure plate from valve. Drill and insert pin (19) to lock the adjustment. Grind off stem projection flush with bottom of pressure plate.

Valve Size	1	1 1/4	1 1/2	2	2 1/2	3	4	5	6
Dimension K	3/64	5/64	1/8	7/64	11/64	1/8	5/32	1/4	5/16

ASSEMBLY

1. Reassemble the valve in the reverse of the procedure described above.
2. When replacing the blind flange gasket (3), clean old gasket material from any serrated surface.
3. Apply a silicone-base lubricant (Dow 55M or equal) to the piston o-ring (13) before reassembly of stem and balance piston.

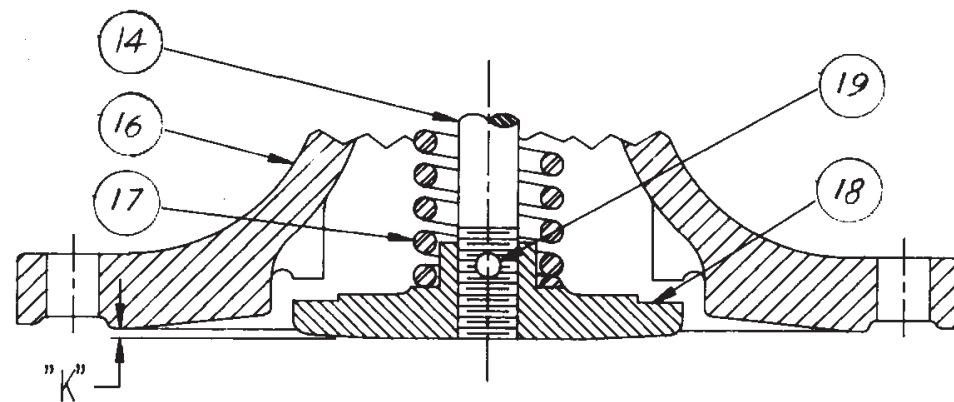

FIGURE 2