

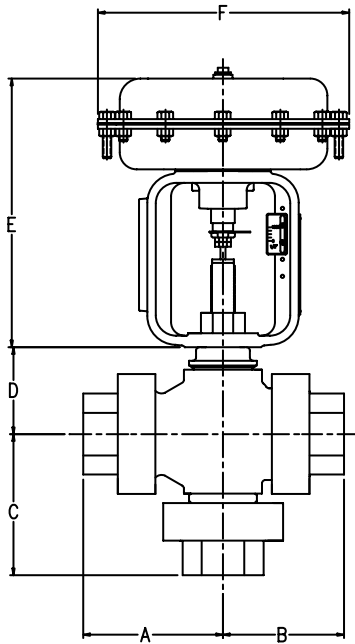

A division of CIRCOR International, Inc.

SPENCE ENGINEERING COMPANY, INC. 150 COLDENHAM ROAD, WALDEN, NY 12586-2035

SD 8013/0508



KOMBAT K3 Control Valve Sizes 1/2" through 2" ANSI CLASS 250

The Kombat K3 Control Valve is designed for economical control of steam, water, gas and process applications in typical institutional, commercial and industrial processes. The Kombat K3 is a 3-way valve available with either a direct or reverse acting actuator that meets most mixing or diverting application requirements.

MAXIMUM RATED FLOW COEFFICIENTS* (Cv)

VALVE SIZE					
1/2	3/4	1	1 1/4	1 1/2	2
5.6	7.1	9.2	22	28	35

DIMENSIONS inches (mm) AND WEIGHTS pounds (kg)

Size	A	B	C	D	E		F		Weight	
					36 in ²	60 in ²	36 in ²	60 in ²	36 in ²	60 in ²
1/2 - 3/4 (15)-(20)	3 5/8 (92)	3 5/8 (84)	4 1/8 (105)	2 7/8 (73)	9 7/8 (251)	-	9 1/4 (235)	-	28 (12.7)	41 (18.6)
1 (25)	3 5/8 (92)	3 5/8 (84)	4 1/8 (105)	2 7/8 (73)	9 7/8 (251)	-	9 1/4 (235)	-	27 (12.3)	40 (18.2)
1 1/4 (32)	4 11/16 (119)	4 1/8 (105)	4 22/32 (119)	3 3/32 (79)	9 7/8 (251)	11 3/4 (298)	9 1/4 (235)	11 1/4 (286)	35 (15.9)	48 (21.8)
1 1/2 (40)	4 11/16 (119)	4 1/8 (105)	4 22/32 (119)	3 3/32 (79)	9 7/8 (251)	11 3/4 (298)	9 1/4 (235)	11 1/4 (286)	37 (16.8)	50 (22.7)
2 (50)	4 7/8 (124)	4 3/8 (106)	4 29/32 (125)	3 3/32 (79)	9 7/8 (251)	11 3/4 (298)	9 1/4 (235)	11 1/4 (286)	42 (19.1)	55 (25)

PRESSURE/TEMPERATURE CHART

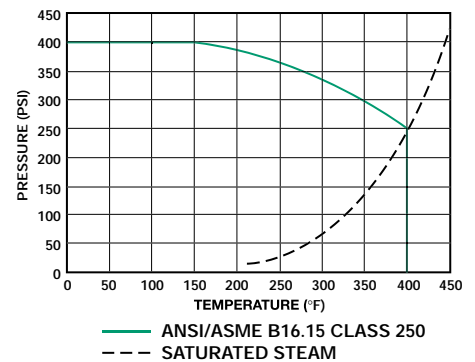

PRINTED IN U.S.A.

Cv TABLE

Percent of Travel			0	10	20	30	40	50	60	70	80	90	100
Valve Size	Travel (In)	Port	Cv										
1/2	7/32	Lower	0	0.9	1.9	2.7	3.6	4.3	4.8	5.2	5.3	5.4	5.6
		Upper	5.6	5.55	5.5	5.3	4.9	4.5	3.9	3.1	2.2	1.2	0
3/4	7/32	Lower	0	0.9	2	3	4	4.9	5.5	6	6.2	6.3	6.4
		Upper	7.1	7	6.9	6.5	5.9	5.2	4.4	3.4	2.3	1.2	0
1	7/32	Lower	0	0.8	1.7	2.9	4	5.3	6.2	7.2	7.8	8.4	8.7
		Upper	9.2	8.5	7.9	7.1	6.2	5.3	4.2	3.2	2.1	1.1	0
1 1/4	1/2	Lower	0	2.7	6.2	10.2	15.0	18.8	20	20.8	21.2	21.6	22
		Upper	19.5	19	18.5	17.5	15.5	13.5	11	8	5	2.5	0
1 1/2	1/2	Lower	0	2	6	11	16	20	22.5	24.5	26	27	28
		Upper	24	23	22	20	18	15	12	9	6	2.7	0
2	1/2	Lower	0	2.2	5.7	10.9	16	21	24	27.4	30	32	34
		Upper	35	32.4	30	27	23.5	20	16	12	8	4	0

OPERATING PRINCIPLE

The Kombat K3 Valve is a three way, universal construction, globe style, pneumatic diaphragm control valve. The pneumatic actuator can be arranged as direct or reverse acting. When selecting a direct acting actuator, upper port is failed closed on air loss. When selecting a reverse acting actuator, the lower port is failed closed on air loss. When used for mixing, the forces developed by the two inlet flows oppose each other and create a balanced environment. Thus, the actuator can control the flow efficiently without power lost to overcome dynamic unbalance. When using the valve for diverting service, simply reverse the valve installation.

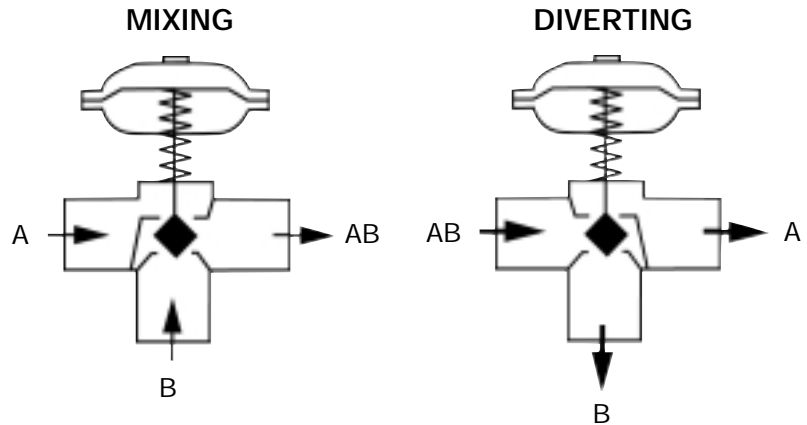

RECOMMENDED INSTALLATION

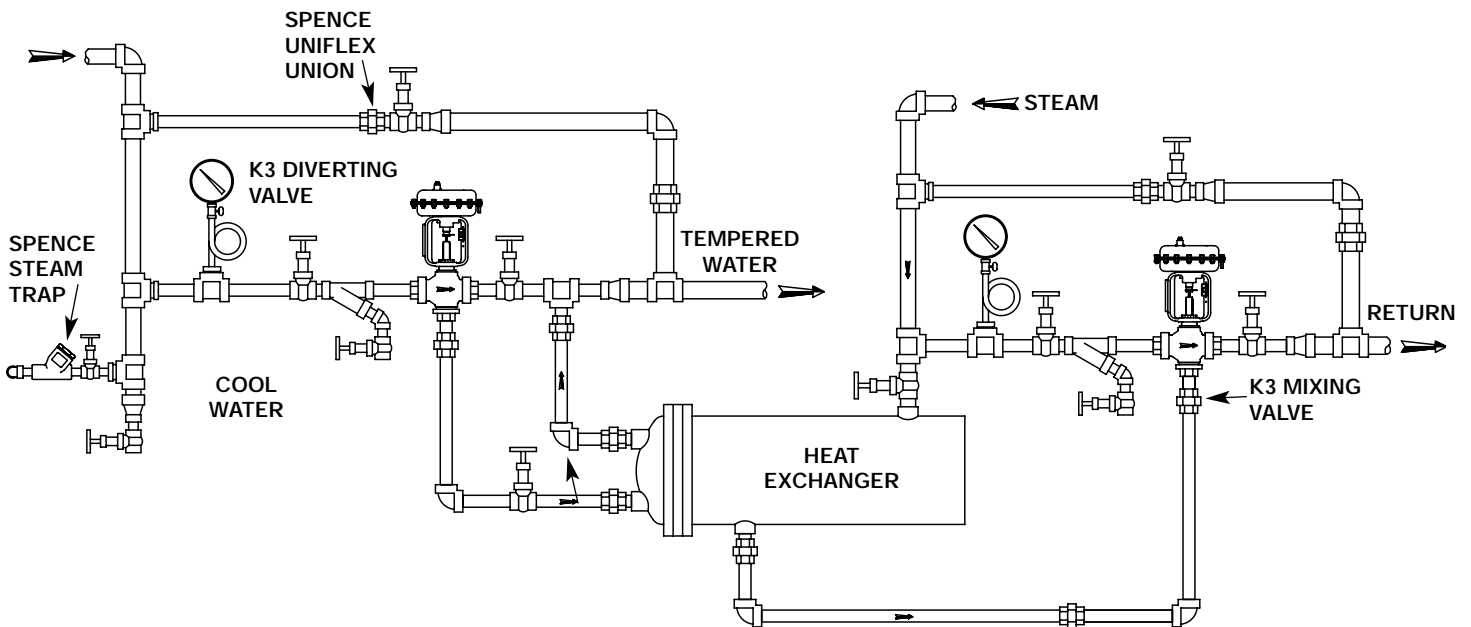

FIGURE 1 - Typical Steam Installation

INSTALLATION

CAUTION!

The piping system must be adequately designed and supported to prevent extraordinary loads to the pressure equipment.

Locate the valve in a straight run of horizontal pipe as shown in Figure 1. The valve should be mounted with the actuator in the upright position. Allow room for removal of the actuator. Prevent pipeline hammering in compressible fluid service by providing proper drainage before and after the valve. Avoid damaging effects of scale and dirt in pipelines by using a strainer. A 3-valve

by-pass to facilitate inspection and maintenance without interrupting service is recommended. To eliminate excessive noise with steam and other compressible fluids, enlarge the delivery pipe size to effect a reasonable flow velocity at the reduced pressure. A concentric transition is recommended. If possible, avoid sharp turns close to the valve and bullheaded tee connections to a low pressure main. Install initial and delivery pressure gauges to indicate performance. If the rating of the delivery system or connected equipment is less than the initial pressure, provide a safety relief valve.

START-UP

Flush piping system thoroughly to clear it of welding beads, scale, sand, etc. Install valve with the arrow on the side of the valve body pointing in the direction of fluid flow. Install controller and accessories in accordance with instructions furnished by the manufacturer of these items. Connect necessary air lines and/or electrical connections to diaphragm chamber and valve mounted

accessories. Use 1/4" O.D. tubing for all air lines. If length of the air line exceeds 25 ft, use 3/8" O.D. tubing. Insulation, if desired, may be applied to the valve body only. Do not insulate bonnet. Caution: Hazardous fluids may be handled by this valve. Only qualified personnel, who are familiar with your installation, should be permitted to install, readjust, inspect or maintain the valve.

TROUBLESHOOTING

For troubleshooting of the controlling device and accessories, see instruction furnished by manufacturer of these items. To troubleshoot valve and actuator, check for the following; change in operating conditions; pneumatic signal failure; diaphragm failure;

foreign matter lodged between seat ring and plug; actuator vent plug may be: plugged, missing, replaced with a solid plug; packing leakage.

K3 ACTUATOR SHUTOFF TABLE

(Refer to Temperature Limits)

Size	Travel	Cv	Act. Size	Bench Range	Reverse Shutoff*		Bench Range	Direct Shutoff**	
					3-15 psi	0-20 psi		3-15 psi	0-20 psi
1/2	7/32	5.6	36	5.5 - 12.5	125	300	4.5 - 13.5	85	400
				6.5 - 11.5	175	375	6 - 12	175	400
				8 - 11	250	400	-	-	-
3/4	7/32	7.1	36	5.5 - 12.5	125	300	4.5 - 13.5	85	400
				6.5 - 11.5	175	375	6 - 12	175	400
				8 - 11	250	400	-	-	-
1	7/32	9.2	36	5.5 - 12.5	75	200	4.5 - 13.5	60	250
				6.5 - 11.5	125	250	6 - 12	125	300
				8 - 11	200	300	-	-	-
1-1/4	1/2	22.0	36	5.5 - 12.5	60	125	6 - 12	80	200
				7.5 - 10.5	110	200	7 - 11	100	225
			60	7.5 - 12	200	300	7 - 11	175	XX
				8 - 11	225	350	-	-	-
1-1/2	1/2	28.0	36	5.5 - 12.5	50	100	6 - 12	60	150
				7.5 - 10.5	85	150	7 - 11	75	175
			60	7.5 - 12	125	250	7 - 11	135	XX
				8 - 11	175	275	-	-	-
2	1/2	35.0	36	5.5 - 12.5	35	75	6 - 12	45	100
				7.5 - 10.5	70	100	7 - 11	60	135
			60	7.5-12	75	175	7-11	100	XX
				8 - 11	125	200	-	-	-

*Lower Port Normally Closed

XX- Not Allowed

**Upper Port Normally Closed

Shutoff pressures are in conformance with ANSI/FCI 70-2 Class III

CAUTION!
K3 is designed for 3-15 psi. Do not exceed 20 psi.

PRODUCT IDENTIFICATION

KOMBAT SERIES K VALVE CODE SELECTION CHART

Model	Orifice Size	Valve Size	Connections	Trim Material	Packing	Actuator	Spring	Positioner	Posit. Set	Accessories						
K	1	T	E	8	1	1 - 3	6	R	B	M - P	0	2	0	1		
1	2	3	4	5	6	7	8	9	10	11	12	13	14	15	16	17

Model - Position 1 & 2 K1 = Bronze, Pneumatic K3 = Bronze, 3 Way, Pneumatic K4 = Cast Iron, Pneumatic K5 = Bronze, Electric, FC K6 = Bronze, Electric, FO K7 = Bronze, 3 Way, Electric
Orifice Size - Position 3 A B C E T

Valve Size - Position 4 C = 1/2 D = 3/4 E = 1 F = 1¼ G = 1½ H = 2 J = 2½ K = 3 M = 4
Connections - Position 5 2 = 125 Flg 8 = Unions
Trim Material - Position 6 1 = Metal

Packing - Position 7 1 = V-ring
Actuator - Position 8 & 9 K1, K3, K4 only 01 = None 36 = 36 sq. in. 60 = 60 sq. in. K5, K6, K7 only 90 = 0-10VDC 91 = 4-20mA 92 = 0-135ohm

Spring - Position 10 & 11 All except K4 DA = Dir 36 DC = Dir 36 DD = Dir 36 DG = Dir 60 FM = Dir 36 RA = Rev 36 RB = Rev 36 RC = Rev 36 RD = Rev 36 RE = Rev 36 DF = Dir 60 DG = Dir 60 RG = Rev 60 K4 only DH = Dir 60 RH = Rev 60 RQ = Rev 60 RT = Rev 60
--

Positioner - Position 12 & 13 A = None MI = Moore I/P MP = Moore P 4P = PMV P4 P 5I = PMV P5 I/P 5P = PMV P5 P
Positioner Set Position 14 & 15 01 = None 02 = 8-15/4-20 mA 03 = 3-9/4-12 mA 04 = 9-15/12-20 mA
Accessories - Position 16 & 17 01 = None 02 = Limit Switch, Mechanical 03 = Limit Switch, Proximity Sw. 04 = Feedback Potentiometer 1K 05 = Feedback 4-20mA Posit. Tra

MAINTENANCE

Warning: Injury or death can occur due to failure to completely isolate valve from all sources of pressure before beginning disassembly. Do not proceed until valve has been completely isolated from process stream and vented to atmosphere.

REMOVAL OF ACTUATOR FROM VALVE BODY ASSEMBLY

Close inlet and outlet stop valves. Be sure valve body is not under pressure. Remove all accessories from control valve. Refer to Figure 2.

Reverse Acting Pneumatic Actuator

Loosen stem nuts (24) and move to approximately 1/3 down valve stem. Re-tighten being careful not to move valve stem. Energize actuator with air to lift the plug off the seat. Disengage lock nut (26) from bonnet (25). De-energize actuator. The actuator and yoke should move away from bonnet. Lift actuator and yoke assembly along with plug (39) off the seat. With an adjustable wrench, unthread valve stem from actuator stem (Fig. 3, #16) until valve stem is disengaged from actuator stem. Remove stem nuts, indicator, packing nut and lock nut.

Direct Acting Pneumatic Actuator

Energize actuator with air slightly (in case of back seating). Loosen stem nuts (24) and re-tighten approximately 1/8" away from actuator stem. Disengage lock nut (26) from bonnet (25). With an adjustable wrench, unscrew valve stem from actuator stem. When valve stem reaches seat, lift actuator (to prevent galling seat and plug). Remove stem nuts, indicator and lock nut.

DISASSEMBLY OF VALVE BODY

Remove stem nuts (24), indicator (32) and lock nut (26). Lift yoke off bonnet (25). To complete body disassembly, unscrew bonnet for K3. Turn stem and plug assembly out of bonnet through packing. Replace packing if necessary. All parts should be inspected for wear and cleaned thoroughly before re-assembling valve body.

DISASSEMBLY OF ACTUATOR

Remove actuator from valve. Remove regular casing bolts (4) and casing nuts (5). Gradually loosen nuts on remaining long casing bolts (14) to allow pre-compression of actuator springs. Remove upper casing (2). Pull actuator stem (16), along with diaphragm (15), springs (3) and piston (13), out through bushing (7). Place a wrench on the machined flats of actuator stem, and remove stem nut (10), seal washer (12) and stem washer (11). Remove o-ring (8) from bushing and replace if necessary. Lubricate o-ring after installing.

RE-ASSEMBLY OF ACTUATOR

Refer to Figure 4 for correct orientation of casings, diaphragm (15), piston (13), stem (16) and springs (3) for direct or reverse action. Be sure piston spring recesses line up between casing ribs as shown in Figure 4. Lubricate bushing O-ring (8) and insert actuator stem through bushing. Re-attach upper casing (2) with long bolts (14) & nuts (5), tightening alternately. Install remaining casing nuts and bolts. Apply air to diaphragm case and check for leakage, full travel and dead band less than .2 psi.

LAPPING PLUG INTO SEAT

Seats and plugs should never require more than the lightest touch up with very fine (400 grit) grinding compound. Heavy lapping will produce galling, a wider seating surface and a groove in the plug, all of which tend to cause leakage. Reface a damaged surface before attempting to grind it in. Lap sparingly. Replace stem and plug (39) in bonnet (25) through packing. Apply lapping compound to plug. Place bonnet on body. After lapping, disassemble and clean all parts thoroughly.

PACKING REPLACEMENT

Check stem for gouges if packing leaks. Replacement packing cartridges can be installed.

RE-ASSEMBLY OF VALVE BODY

Insert plug and then tighten bonnet (25) to body. Note that "R" on body must be up for sizes 1/2" - 1" and the "D" up for sizes 1-1/4" - 2". Install Inlet (42). Replace yoke (9), lock nut (26), stem nuts (24) and travel indicator (32) over stem (34).

REPLACING ACTUATOR ON VALVE BODY - PNEUMATIC

Put actuator assembly over valve stem. Place lock nut (Fig. 2, #26), and stem nuts (24) with travel indicator (32) on valve stem. Rest actuator stem (16) on valve stem. Tighten stem nuts approximately 2/3 down valve stem. Lift actuator assembly and engage valve stem with actuator stem (be careful not to gall plug & seat).

Reverse Acting

When sufficient engagement is met, the actuator can be energized with air to place the yoke on the bonnet (25) and lift the plug off the seat. Tighten lock nut and packing nut.

Direct Acting

Engage valve stem with actuator stem so no contact is made between plug and seat when bottom of yoke is rested on bonnet. Tighten lock nut.

ACTUATOR ADJUSTMENT - PNEUMATIC

Close inlet and outlet stop valves. Be sure valve body is not under pressure. Place a wrench on the machined flats of actuator stem (16). Counter two stem nuts (24) approximately halfway down the threads of the stem (34).

Reverse Acting

Apply sufficient air pressure to diaphragm case to start moving valve through its rated travel. This is shown by travel indicator (32). Engage lower stem nut (24) and turn body stem (34) into actuator stem (16) until pre-compression of actuator springs (3) is relieved (plug should not be seating on seat ring when air pressure is removed from actuator case). Apply prescribed setting pressure to actuator. This is determined by specific operating conditions. Turn body stem out of actuator stem until plug seats on seat ring (28). To prevent galling, do not turn body stem after plug has contacted seat ring. Turn stem nuts up plug & stem assembly and tighten to lock them in position. Reduce air signal to 0 psi and calibrate indicator scale (20). Check that full travel is achieved with a 15 psi signal.

Direct Acting

Engage lower stem nut (24) and turn body stem (34) into actuator stem (16) until plug & stem assembly stops at upper limit of travel and/or a slight downward movement of actuator stem is detected. Turn stem nuts up body stem and tighten them to lock in position. Calibrate indicator scale (20). Check that full travel is achieved at a 3 psi signal.

It is solely the responsibility of the system designer and the user to select products and materials suitable for their specific application requirements and to ensure proper installation, operation and maintenance of these products. Assistance shall be afforded with the selection of the materials based on the technical information supplied to Spence Engineering Company, Inc.; however, the system designer and user retain final responsibility. The designer should consider applicable Codes, material compatibility, product ratings and application details in the selection and application. Improper selection, application or use of the products described herein can cause personal injury or property damage. If the designer or user intends to use the product for an application or use other than originally specified, he must reconfirm that the selection is suitable for the new operating conditions.

VALVE BODY ASSEMBLY PART NUMBERS

ITEM	PART NAME	QTY	MATERIAL	½"	¾"	1"	1¼"	1½"	2"
23A*	STEM BOLT - SHORT	1	BRASS	4-17277-0	4-17277-0	4-17277-0	4-17277-0	4-17277-0	4-17277-0
23B**	STEM BOLT - LONG	1	BRASS	4-17281-00	4-17281-00	4-17281-00	4-17281-00	4-17281-00	4-17281-00
24	STEM NUT	2	BRASS	05-17342-00	05-17342-00	05-17342-00	05-17342-00	05-17342-00	05-17342-00
25	BONNET	1	BRASS	558B107-02	558B107-02	558B107-02	558B110-02	558B110-02	558B110-02
26	LOCK NUT	1	ST STL	05-17330-00	05-17330-00	05-17330-00	05-17330-00	05-17330-00	05-17330-00
27	WAVE WASHER	1	ST STL	122A155-01	122A155-01	122A155-01	122A155-02	122A155-02	122A155-02
28	SEAT	1	ST STL	562A114-01	562A114-01	562A114-02	562A114-03	562A114-04	562A114-05
29	UNION TAILPIECE	3	GALV IRON	SZ227	SAA227	SMP463	SBB227	SMP465	SMP593
30	BODY	1	BRONZE	SAM1167B	SAM1167B	SAM1167B	SAN1167B	SAN1167B	564B116-01
31	ADAPTER	1	ST STL	141A166	141A166	141A166	141A166	141A166	141A166
32	TRAVEL INDICATOR	1	ALUM	05-12962-00	05-12962-00	05-12962-00	05-12962-00	05-12962-00	05-12962-00
33	V RING PACKING SET	1	TFE/SS/VITON	204A104-01	204A104-01	204A104-01	204A104-01	204A104-01	204A104-01
34	STEM	1	ST STL	552A110-03	552A110-03	552A110-03	552A114-03	552A114-03	552A114-03
35	YOKE BUSHING	1	BRASS	04-17278-00	04-17278-00	04-17278-00	04-17278-00	04-17278-00	04-17278-00
36	SPACER	1	BRASS	04-17280-00	04-17280-00	04-17280-00	04-17280-00	04-17280-00	04-17280-00
37	BONNET GUIDE	1	BRASS	556A113-01	556A113-01	556A113-01	556A113-01	556A113-01	556A113-01
38	GUIDE	1	ST STL	556A111-01	556A111-01	556A111-01	556A111-02	556A111-02	556A111-02
39	PLUG	1	ST STL	554A151-01	554A151-01	554A151-02	554A151-03	554A151-04	554A151-05
40	UNION NUT	3	GALV IRON	SMP468	SMP468	SMP468	SMP470	SMP470	SMP592
41	GUIDE	1	BRASS	SK832	SK832	SK832	SL832	SL832	SM832
42	INLET	1	BRONZE	562B105-01	562B105-01	562B105-02	562B106-01	562B106-02	562B106-03

* Not included in body assembly; order K-KIT separately.

**Not included in body assembly; order separately.

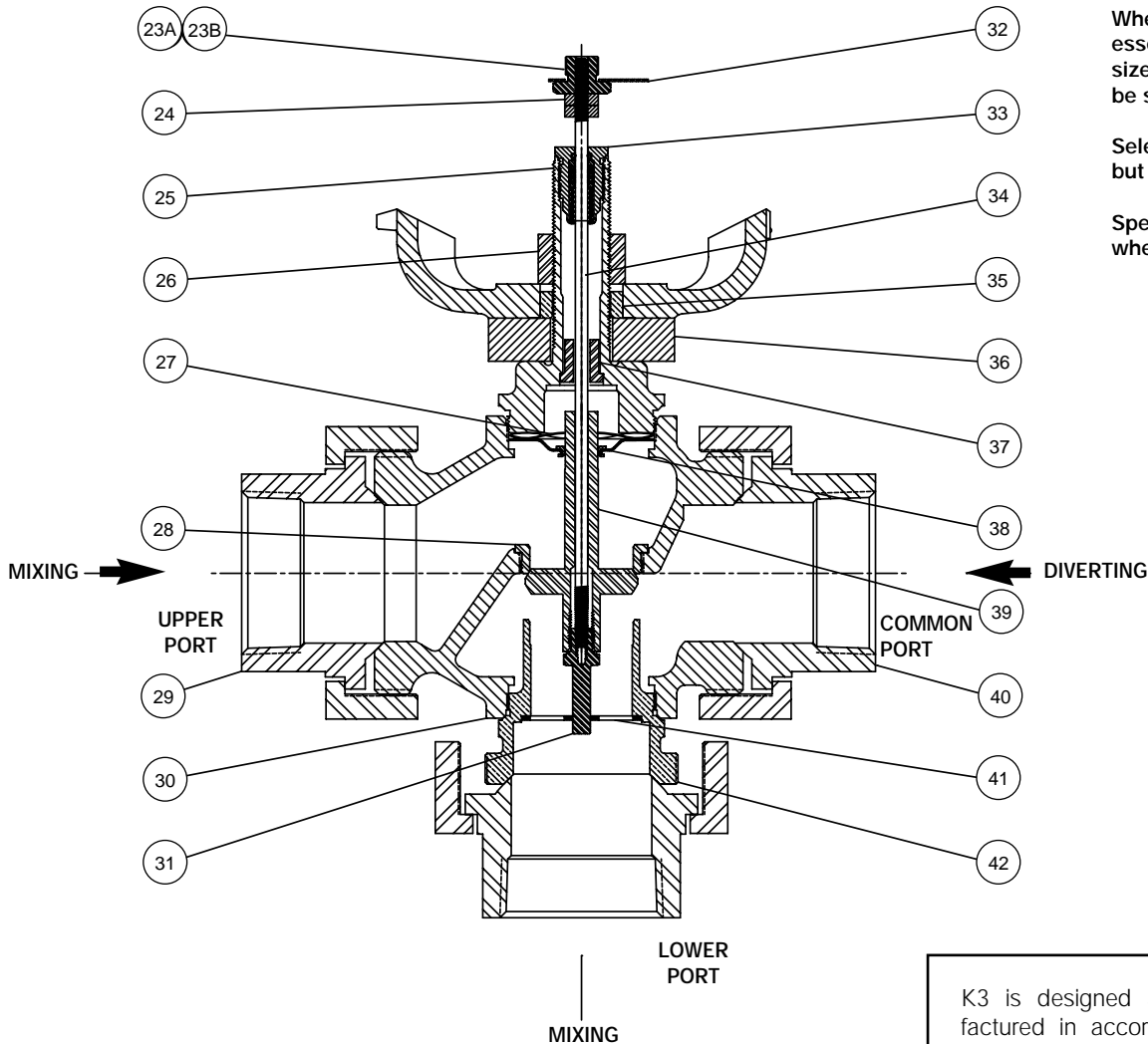

When ordering parts, it is essential that the valve type, size, service and serial number be stated.

Select part by item number, but order by part number.

Specify complete part number when ordering.

**FIGURE 2
VALVE BODY ASSEMBLY**

K3 is designed and manufactured in accordance with Article 3, Section 3 of the Pressure Equipment Directive.

ACTUATOR PART NUMBERS

ITEM #	PART NAME	MATERIAL	PART #	QTY
1	Vent plug	H.D.poly	—	1
2	Upper casing	Stl/powder coat	—	1
3	Springs	Steel	See Below	See Below
4	Casing bolt standard	304 ss	—	10/14
5	Casing nut	316ss	—	12/16
6	Lower casing	Stl/powder coat	—	1
7	Bushing	Bronze	—	1
*8	O Ring	Buna-n	05-04017-00	1
9	Yoke	Cl/powder coat	—	1
*10	Stem nut	Steel	05-13374-00	1
*11	Stem washer	316 ss	05-12963-00	1/3
*12	Seal washer	Steel	05-13203-00	1
13	Piston	316 ss	—	1
14	Casing bolt long	304 ss	05-04889-00	2
*15	Diaphragm - 36 sq. in.	Nitrile	0@-12968-00	1
	Diaphragm - 60 sq. in.		0@-12986-00	1
16	Actuator stem	303 ss	—	1
17	Machine screw	Steel	—	3
*18	Casing gasket	Buna-n	05-12566-00	1
19	Machine screw	Steel	—	2
20	Indicator scale	Aluminum	05-17470-00	1
21	Specification plate	Aluminum	05-13199-00	1

ACTUATOR REPAIR KIT PART NUMBERS

36 SQ. IN.	60 SQ. IN.
51447	51448

*These parts furnished in Actuator Repair Kit.

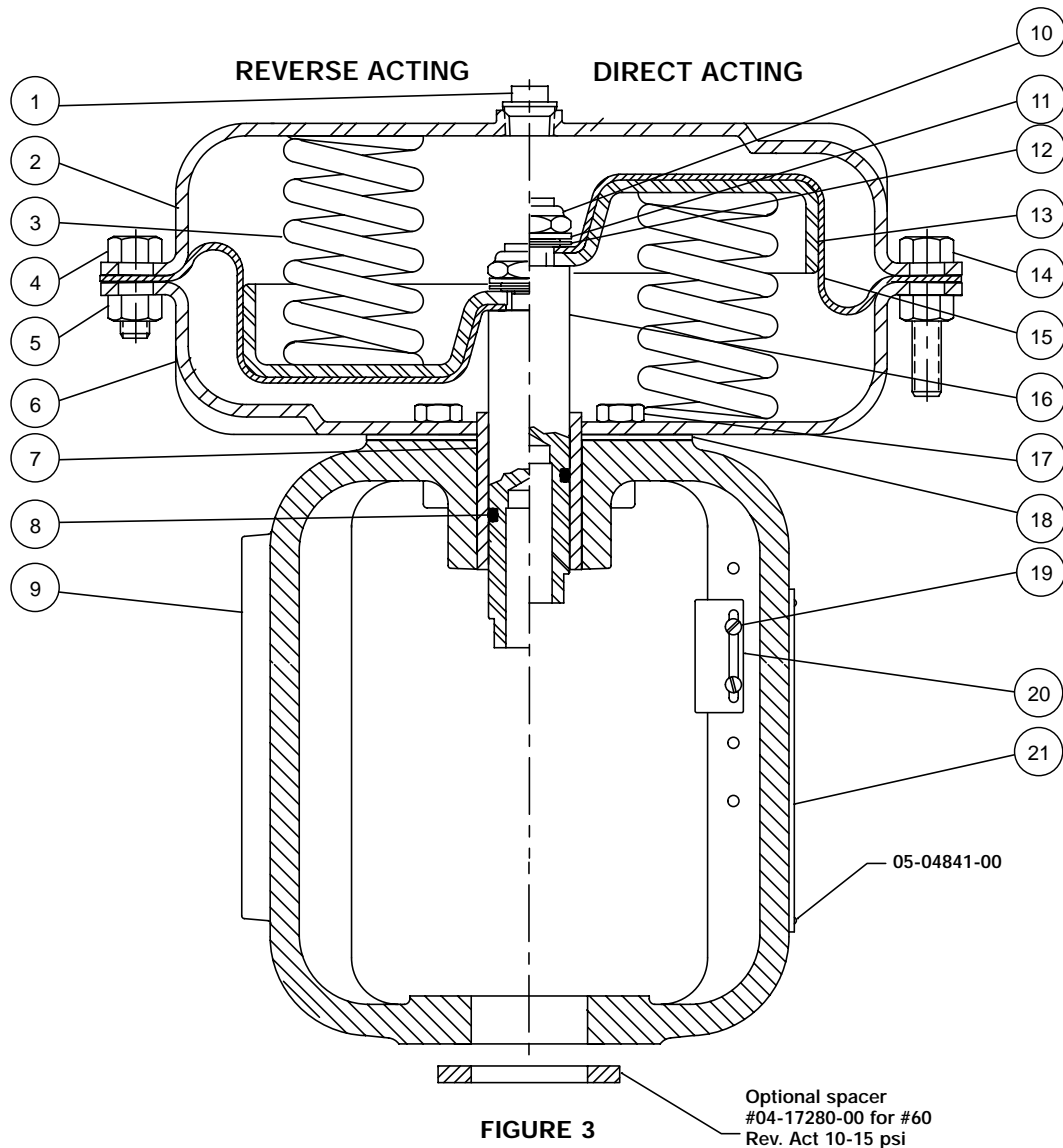

ACTUATOR SPRING KITS

Part #		Reverse-Lower Port Normally Closed				Direct-Upper Port Normally Closed				Spring Kit Includes:			
		7/32" Travel		1/2" Travel		7/32" Travel		1/2" Travel		Spring			Other
Part #	Notes	Code	Range	Code	Range	Code	Range	Code	Range	QTY	Color	Part #	
36KIT098	(1)	-	-	-	-	36DM	4.5-13.5	-	-	6	SILVER	05-05007-00	-
36KIT100	(1)	36RA	5.5-12.5	-	-	36DA	6-12	-	-	6	YELLOW	05-12991-00	-
36KIT102	(1)	36RB	6.5-11.5	-	-	-	-	-	-	6	YELLOW	05-12992-00	-
36KIT104	(2)	36RC	8-11	36RC	5.5-12.5	-	-	36DC	6-12	6	RED	05-13090-01	-
36KIT106	(1)	-	-	-	-	-	-	36DD	7-11	4	RED	05-13090-01	-
36KIT108	(2)	-	-	36RE	7.5-10.5	-	-	-	-	6	GREEN	05-13085-00	05-04889-00 (2) Bolts
60KIT100	(3)	-	-	60RG	7.5-12	-	-	60DG	7-11	6	BROWN	05-13093-01	-
60KIT102	(2)	-	-	60RH	8-11	-	-	-	-	4	BROWN	05-13093-01	-

¹ For Direct Shutoff - Invert Springs, Piston and Diaphragm from Reverse Shutoff Actuator.

(1) Mounts using KKIT-1

(2) Mounts using KKIT-2

(3) Mounts using KKIT-4

K3 ACTUATOR CONNECTOR KITS

PART #	SIZE	KKIT Includes:		
		Stem Bolt	Bushing	Spacer
KKIT-1	1/2 - 2	04-17277-00	04-17278-00	-
KKIT-2	1/2 - 2	04-17281-00	04-17278-00	-
KKIT-4	1/2 - 2	04-17277-00	04-17278-00	04-17280-00

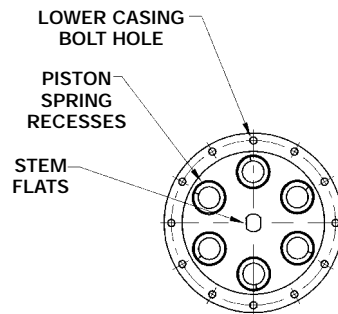

FIGURE 4
PISTON DIAPHRAGM ASSEMBLY