

SHARPE[®] VALVES

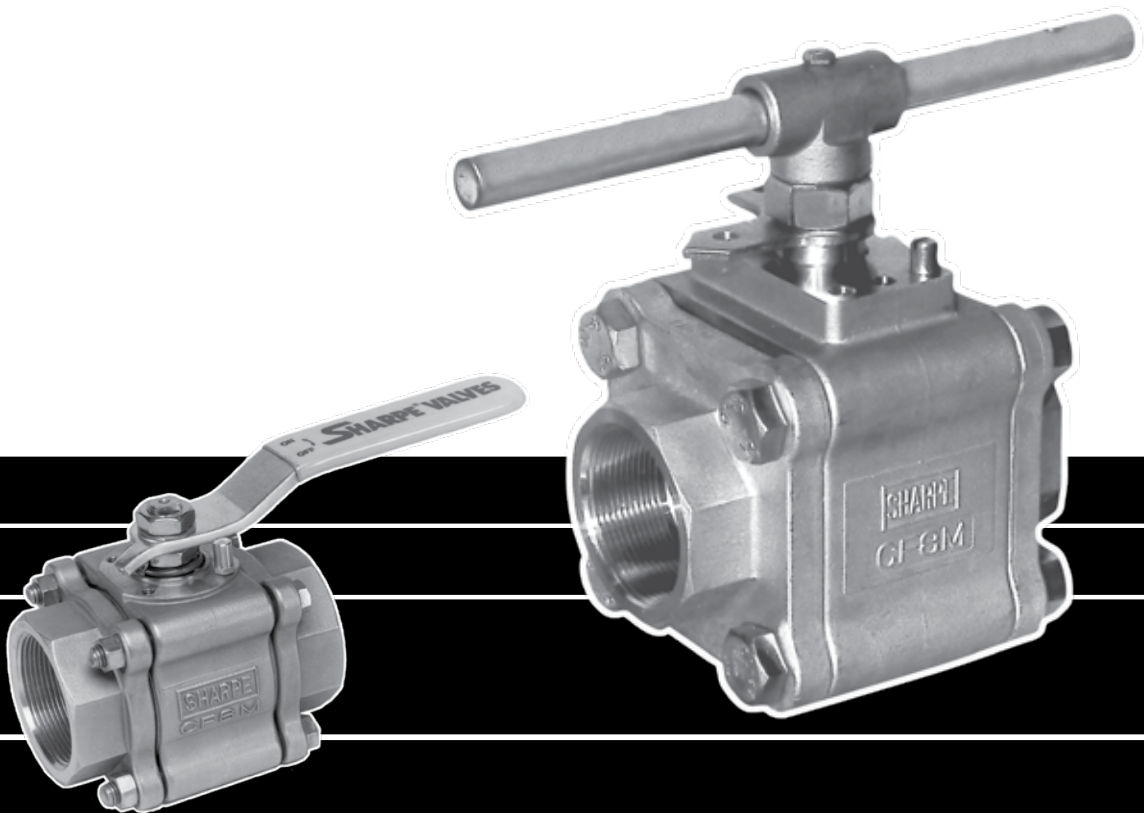

**SERIES FS 84/99
FIRE SAFE HIGH PERFORMANCE
3 PIECE BALL VALVES**

SHARPE® FIRE SAFE API 607 4th EDITION HIGH PERFORMANCE VALVES

Sharpe® Series FS 84 /99 Standard and Full Port Ball Valves offer as standard features, advantages that other valve manufacturers offer only as costly extras. This is the Sharpe® advantage.

3-Piece Design

In-line serviceable swing-out center section allows easy access to internal valve components without disturbing alignment of pipe. Functions as both valve and union.

Bottom Entry Live Loaded Stem

Self adjusts with pressure and temperature fluctuations. Blow-out proof anti-static design helps prevent accidents and injuries.

Live Loaded High Cycle Stem

Two belleville washers in manual valve and four belleville washers in actuated valve allow the valves to perform exceptionally during high cycling and in control applications.

Fully Encapsulated Body Seals

Allows valve ends to be welded in line without disassembly, saving costly labor time. Also prevents seal ruptures in high pressure or steam applications.

Integral Mounting Pad

Ideal for actuation. Centering lip feature assures precise alignment of bracket, stem and coupler. Actuators may be retrofitted on existing series FS 84/99 without disruption of line integrity. Allows for secondary containment unit to be added when necessary.

Lockable Handle

All Sharpe® Series FS 84/99 Valves meet OSHA standards with locking device. Keeps valves from being opened or closed accidentally.

Slotted Seat Design

Relief slots help equalize body pressure, reduce torque and assure leak-tight sealing. Seats also provide a wiping action that cleans ball and seats each time valve is cycled.

Choice of Seats

A wide variety of seat materials are readily available for the most demanding applications, including Nova*, PEEK, TFE, RTFE, and TFM™. Stem packing and body seals are Grafoil.

Variety of End Combinations

A wide choice of optional end connections are available including, but not limited to threaded ends, socket weld ends, butt weld ends, flush bottom tank pads, grooved ends and 150#/300# flanges.

Floating Ball Design

Precision engineered solid stainless steel ball with relief hole in stem slot prevents build up of cavity pressure while valve is in open position. Bi-directional floating ball seats downstream reducing torque and guaranteeing a bubble-tight shut off.

Encapsulated Body Bolts

Heavy duty stainless steel bolting is protected from outside environment assuring valve integrity.

Traceability

Heat numbers are provided on all valve bodies and ends. CMTR's (certified mill test reports) are available upon request.

Fire Safe API 607 4th Edition

A metal centering ring is part of the end cap that fits into the body (tongue and groove) and aligns the pipe end with the ball. During fire, the seat is destroyed and the ball moves downstream where it makes contact with a special shaped end that provides a secure fire tight seal.

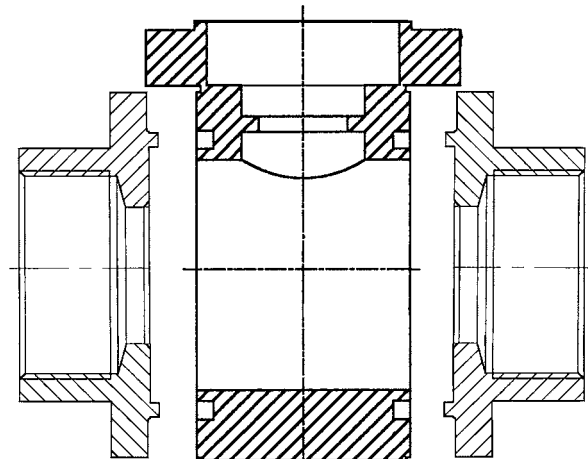

* Carbon and Graphite Filled TFE

** TFM is a registered trademark of Dyneon, LLC

SERIES FS 84/99

VALVE PARTS AND IDENTIFICATION

FS84
1/4", 3/8", 1/2"

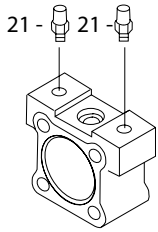

FS 84 3/4" - 2-1/2"
FS 99 1/2" - 2"

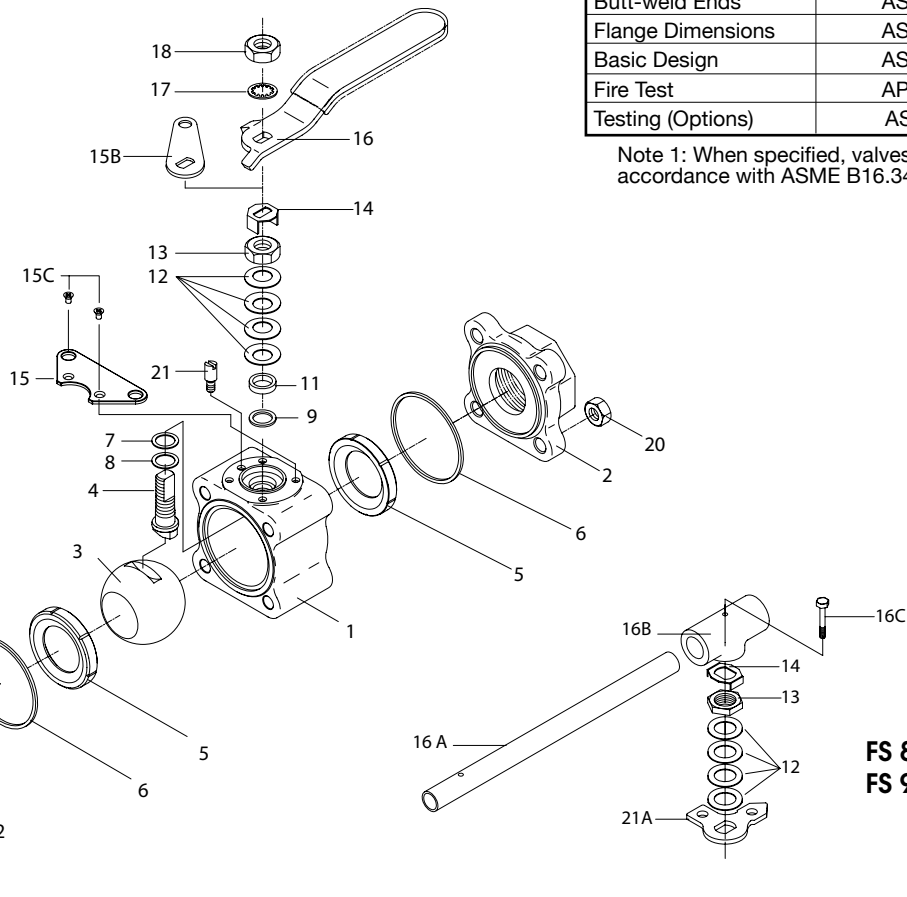

FS 84 2-1/2"
FS 99 2"

APPLICABLE STANDARDS

| | |
|---------------------|----------------------|
| Body Wall Thickness | ASME B16.34 |
| SW & Threaded Ends | ASME B16.11 |
| Butt-weld Ends | ASME B16.25 |
| Flange Dimensions | ASME B16.5 |
| Basic Design | ASME B16.34 (note 1) |
| Fire Test | API 607 4th Edition |
| Testing (Options) | ASME B16.34 API 598 |

Note 1: When specified, valves can be furnished in accordance with ASME B16.34 requirements.

| PART NO. | PART | QTY. | MATERIAL |
|----------|-------------------|------|--|
| 1 | Body | 1 | 316 Stainless Steel Alloy 20 Carbon Steel Hastelloy C Monel |
| 2 | Pipe Ends | 2 | 316L Stainless Steel Alloy 20 Carbon Steel Hastelloy C Monel |
| 3 | Ball | 1 | 316 Stainless Steel Monel |
| 4 | Stem | 1 | 316 Stainless Steel Hastelloy C |
| 5 | Valve Seat | 2 | TFE Nova* |
| 6 | Body Seal | 2 | Grafoil |
| 7 | Thrust Bearing | 1 | Nova* |
| 8 | Thrust Bearing | 1 | PEEK |
| 9 | Stem Packing | 1 | Grafoil |
| 11 | Packing Gland | 1 | Stainless Steel |
| 12 | Belleville Washer | 4 | Stainless Steel |
| 13 | Packing Nut | 1 | Stainless Steel |

| PART NO. | PART | QTY. | MATERIAL |
|----------|--|--------|------------------------------------|
| 14 | Lock Tab | 1 | Stainless Steel |
| 15 | Lower Lock Latch | 1 | Stainless Steel |
| 15B | Upper Lock Latch | 1 | Stainless Steel |
| 15C | Latch Bolt | 1 | Stainless Steel |
| 16 | Handle 1/4"-2" Std. Port 1/2"-1-1/2" F. Port | 1 | Stainless Steel |
| 16A | Wrench 2-1/2" Std. Port 2" Full Port | 1 | Cad Plate Carbon Steel |
| 16B | Wrench Block | 1 | Stainless Steel |
| 16C | Hex Head Bolt | 1 | Stainless Steel |
| 17 | Lock Washer | 1 | Stainless Steel |
| 18 | Handle Nut (1/4"-2") | 1 | Stainless Steel |
| 19 | Body Bolts | 4 | Stainless Steel |
| 20 | Nuts | 4 | Stainless Steel |
| 21 | Stop Pin (1/4"-1/2") | 1 2 | Stainless Steel Stainless Steel |
| 21A | Stopper | 1 | Stainless Steel |

* Nova: Carbon and Graphite Filled TFE

SERIES FS 84/99

DIMENSIONS

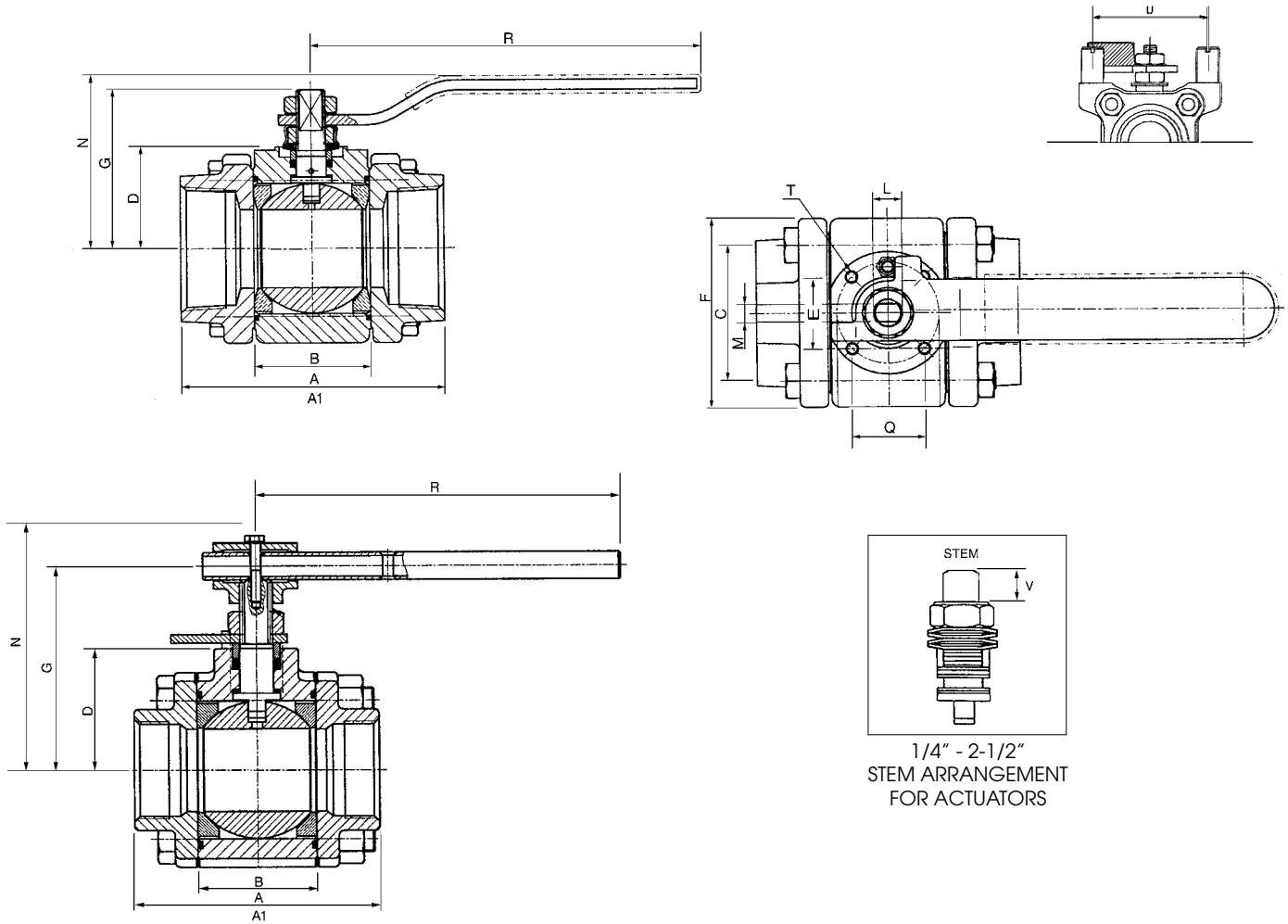

SERIES FS84 - Standard Port

| SIZE | A | A1(BW) | B | C | D | E | F | G | L | M | N | Q | R | T | U | V |
|--------|------|--------|------|------|------|------|------|------|--------------|-----|------|------|-------|-------------|------|-----|
| 1/4" | 2.54 | 2.62 | .813 | 1.25 | .939 | - | 1.75 | 1.50 | 3/8"-24 UNF | .22 | 1.76 | - | 4.62 | 1/4"-20 UNC | 1.90 | .28 |
| 3/8" | 2.54 | 2.62 | .813 | 1.25 | .939 | - | 1.75 | 1.50 | 3/8"-24 UNF | .22 | 1.76 | - | 4.62 | 1/4"-20 UNC | 1.90 | .28 |
| 1/2" | 2.54 | 2.62 | .813 | 1.25 | .939 | - | 1.75 | 1.50 | 3/8"-24 UNF | .22 | 1.76 | - | 4.62 | 1/4"-20 UNC | 1.90 | .28 |
| 3/4" | 2.78 | 2.87 | .969 | 1.50 | 1.24 | 1.00 | 2.05 | 1.59 | 3/8"-24 UNF | .22 | 1.87 | 1.00 | 4.50 | M5 | - | .28 |
| 1" | 3.68 | 3.72 | 1.25 | 1.75 | 1.51 | 1.18 | 2.42 | 2.19 | 7/16"-20 UNF | .30 | 2.40 | 1.18 | 5.75 | M5 | - | .30 |
| 1-1/4" | 4.22 | 4.24 | 1.63 | 2.00 | 1.65 | 1.18 | 2.70 | 2.38 | 7/16"-20 UNF | .30 | 2.70 | 1.18 | 5.75 | M5 | - | .30 |
| 1-1/2" | 4.55 | 4.58 | 1.91 | 2.25 | 1.71 | 1.38 | 3.16 | 2.88 | 9/16"-18 UNF | .35 | 3.16 | 1.38 | 7.00 | M6 | - | .42 |
| 2" | 5.00 | 5.03 | 2.22 | 2.62 | 1.87 | 1.38 | 3.56 | 3.06 | 9/16"-18 UNF | .35 | 3.35 | 1.38 | 7.00 | M6 | - | .42 |
| 2-1/2" | 5.86 | 5.86 | 2.86 | 3.35 | 2.92 | 2.75 | 4.57 | 4.56 | M20 | .55 | 5.58 | 1.25 | 10.00 | M8 | - | .55 |

SERIES FS99 - Full Port

| SIZE | A | A1(BW) | B | C | D | E | F | G | L | M | N | Q | R | T | V |
|--------|------|--------|------|------|------|------|------|------|--------------|-----|------|------|-------|----|-----|
| 1/2" | 2.78 | 2.87 | .969 | 1.50 | 1.24 | 1.00 | 2.05 | 1.59 | 3/8"-24 UNF | .22 | 1.87 | 1.00 | 4.50 | M5 | .28 |
| 3/4" | 3.68 | 3.72 | 1.25 | 1.75 | 1.51 | 1.18 | 2.42 | 2.19 | 7/16"-20 UNF | .30 | 2.40 | 1.18 | 5.75 | M5 | .30 |
| 1" | 4.22 | 4.24 | 1.63 | 2.00 | 1.65 | 1.18 | 2.70 | 2.38 | 7/16"-20 UNF | .30 | 2.70 | 1.18 | 5.75 | M5 | .30 |
| 1-1/4" | 4.55 | 4.58 | 1.91 | 2.25 | 1.71 | 1.38 | 3.16 | 2.88 | 9/16"-18 UNF | .35 | 3.16 | 1.38 | 7.00 | M6 | .42 |
| 1-1/2" | 5.00 | 5.03 | 2.22 | 2.62 | 1.87 | 1.38 | 3.56 | 3.06 | 9/16"-18 UNF | .35 | 3.35 | 1.38 | 7.00 | M6 | .42 |
| 2" | 5.86 | 5.86 | 2.86 | 3.35 | 2.92 | 2.75 | 4.57 | 4.56 | M20 | .55 | 5.58 | 1.25 | 10.00 | M8 | .55 |

SERIES FS 84

PERFORMANCE DATA

| VALVE SIZE | FLOW COEFF. Cv | EQUIVALENT LENGTH OF SCH. 40 PIPE FEET | APPROX. WEIGHT | PORT SIZE |
|------------|----------------|--|----------------|-----------|
| 1/4" | 8 | 1.9 | 1.20 | .44 |
| 3/8" | 8 | 1.9 | 1.20 | .44 |
| 1/2" | 8 | 1.9 | 1.20 | .44 |
| 3/4" | 12 | 6.3 | 1.70 | .56 |
| 1" | 32 | 3.1 | 3.00 | .81 |
| 1-1/4" | 46 | 6.3 | 4.00 | 1.00 |
| 1-1/2" | 80 | 4.3 | 6.00 | 1.25 |
| 2" | 120 | 7.5 | 8.00 | 1.50 |
| 2-1/2" | 240 | 5.00 | 25.00 | 2.00 |

SERIES FS 99

PERFORMANCE DATA

| VALVE SIZE | FLOW COEFF. Cv | EQUIVALENT LENGTH OF SCH. 40 PIPE FEET | APPROX. WEIGHT | PORT SIZE |
|------------|----------------|--|----------------|-----------|
| 1/4" | 8 | .9 | 1.8 | .44 |
| 3/8" | 8 | .9 | 1.8 | .44 |
| 1/2" | 38 | 1.4 | 1.8 | .56 |
| 3/4" | 71 | 1.0 | 3.0 | .81 |
| 1" | 110 | 1.9 | 5.7 | 1.00 |
| 1-1/4" | 230 | 2.1 | 6.2 | 1.25 |
| 1-1/2" | 350 | 2.1 | 7.5 | 1.50 |
| 2" | 600 | 2.1 | 29.0 | 2.00 |

SEAT PRESSURE/TEMPERATURE RATING SERIES FS84

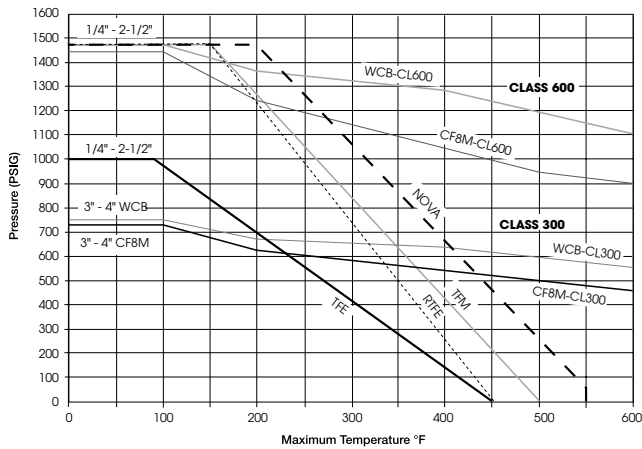

SEAT PRESSURE/TEMPERATURE RATING SERIES FS99

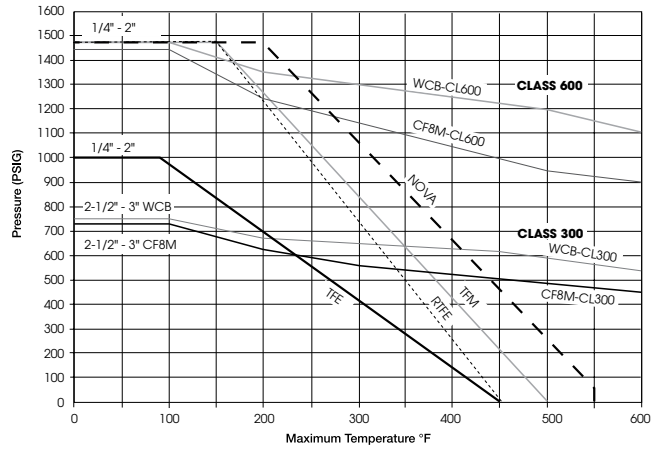

SHARPE® VALVES

Choose from our full line of high quality valves and actuators to meet your needs.

Whatever your flow control requirements are, Sharpe® has the right products and service to meet your needs today.



HOW TO ORDER

| VALVE SIZE | VALVE SERIES | BODY & ENDS | BALL & STEM | SEAT | SEAL | ENDS | OPTIONS |
|------------|----------------------|---------------------|-----------------|--------------------|-------------|-------------------------------------|--|
| 1/4" | FS 84 (Std. Port) | 4 = Carbon Steel | 6 = 316 S/S | T = TFE | G = Grafoil | TE = Threaded Ends (NPT) | X= Oxygen Service |
| 3/8" | | 6 = Stainless Steel | 2 = Alloy 20 | R = Reinforced TFE | | TEB = Threaded Ends (BSPT) | |
| 1/2" | FS 99 (Full Port) | 2 = Alloy 20 | 3 = Monel | N = Nova | | BW = Butt Weld Sch. 5, 10, 40, & 80 | F = Fugitive Emissions Certified ANSI 593.00.01 |
| 3/4" | | 3 = Monel | 5 = Hastelloy C | M = TFM™ | | SW = Socket Weld | E = Extended Stem |
| 1" | | 5 = Hastelloy C | | | | FBE = Flush Bottom Tank Flange | L = Lockable Extended Stem |
| 1-1/4" | | | | | | | D = Leak Detection Stem |
| 1-1/2" | | | | | | | GO = Gear Operator |
| 2" | | | | | | | 7 = 17-4PH Stem |
| 2-1/2" | | | | | | A = Nace | |



SHARPE® VALVES
A Division of Smith-Cooper International, LLC

Toll-Free 1-877-7SHARPE
(877) 774-2773
Fax: (708) 562-9250
E-Mail: info@sharpevalves.com
www.sharpevalves.com
1260 Garnet Drive
Northlake, Illinois 60164 U.S.A.