



MAX-FLO

SUPER HIGH CAPACITY FLOAT & THERMOSTATIC STEAM TRAPS

Pressures to 175 PSIG (12.1 barg)
Temperatures to 377°F (192°C)

- High Capacities
- Rugged cast iron body and cover
- Stainless steel thermostatic element eliminates air binding
- Stainless steel float and lever mechanism
- Below condensate level seat design prevents steam leakage
- Resistant to water hammer and corrosion
- In-Line repairable

APPLICATIONS

- Very High Condensate Loads
- Continuous Drainage With High Air Venting Capacity Requirements
- Industrial And Commercial Applications
- Absorption Systems
- Air Handling Coils
- Heat Exchangers
- Dryers Evaporators
- Hot water Generators
- Rendering Machines
- Steam Process Equipment
- Air Make-up Coils
- Unit Heaters And Cooking Kettles

MODELS

- HC-15 - Steam pressures to 15 PSIG
- HC-30 - Steam pressures to 30 PSIG
- HC-75 - Steam pressures to 75 PSIG
- HC-125 - Steam pressures to 125 PSIG
- HC-175 - Steam pressures to 175 PSIG

Installation Tip: Always install STV Test & Block Valve as part of trap station
SEE PAGE 118

Installation Tip: Add Uniflex Pipe Coupling for ease of maintenance
SEE PAGE 102

OPERATION

During startup, air and non-condensable gases enter the trap and are automatically vented through an accurate balanced pressure internal thermostatic air vent. As condensate enters the trap, the float and lever mechanism is raised, lifting the valve off

the seat, discharging the condensate. Condensate will continue to be discharged at the same rate at which it is entering. Any air or non-condensable gas that may accumulate will be continually and efficiently passed by the thermostatic air vent.

MAX-FLO

SUPER HIGH CAPACITY FLOAT & THERMOSTATIC STEAM TRAPS

SPECIFICATION

Steam trap shall be of float and thermostatic design. Float shall actuate the valve via a hinged lever and linkage. Air vent shall be of balanced pressure design with stainless steel welded encapsulated bellows capable of discharging air and noncondensable gases continuously. Trap shall be cast iron bodied suitable for pressures to 175 PSI and shall be a _____ NPT connection.

MAXIMUM OPERATING CONDITIONS

PMO: Max. Operating Pressure see orifice selection
 TMO: Max. Operating Temperature saturated at pressure
 PMA: Max. Allowable Pressure 175 PSIG (12.1 barg)
 PMA: Max. Allowable Pressure 377°F (192°C)

MATERIALS OF CONSTRUCTION

Body & CoverCast Iron 30,000 psi tensile
 Valve Pin and SeatStainless Steel (Hardened)
 FloatStainless Steel
 Lever AssemblyStainless Steel
 Thermostatic Air VentStainless Steel Cage & Thermal Element
 Cover BoltsGrade 5
 BaffleStainless Steel (2-1/2" (65mm) units only)

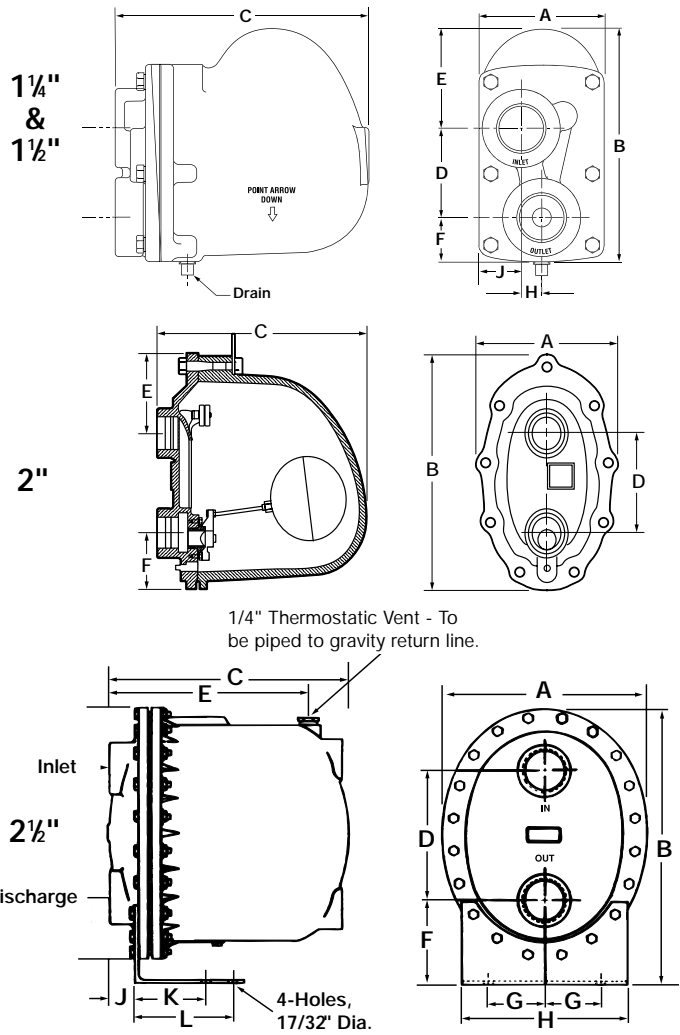

Dimensions													Weight lbs (kg)
MODEL	NPT Size in. (mm)	A	B	C	D	E	F	G	H	J	K	L	
HC-175	1 1/4 & 1 1/2 (32 & 40)	4 1/2 (108)	8 5/8 (211)	8 3/8 (217)	3 (76)	3 3/8 (86)	2 (51)	—	4 5/8 (17.8)	1 3/8 (35)	—	—	18 (8)
ALL	2 (50)	10 (254)	15 (381)	15 1/2 (394)	6 3/8 (168)	4 3/4 (121)	3 1/2 (89)	—	—	—	—	—	108 (49)
ALL	2 1/2 (65)	14 1/2 (368)	20 1/4 (514)	17 3/8 (441)	9 1/2 (241)	14 1 5/8 (379)	6 1/4 (159)	5 (127)	12 (305)	1 3/8 (41)	4 1/2 (114)	7 (178)	175 (79)

Maximum Capacity-lbs/hr																			
Trap	Orifice Max ΔP	Differential - PSIG (barg)																	
		1/4 (0.017)	1/2 (0.035)	1 (0.07)	2 (0.14)	5 (0.35)	10 (0.69)	15 (1.0)	20 (1.4)	25 (1.69)	30 (2.1)	40 (2.8)	50 (3.5)	60 (4.2)	75 (5.2)	100 (6.9)	125 (8.6)	150 (10.4)	175 (12.1)
HC-15, 2"	.970	6500	8000	9500	10800	15500	20900	24000											
HC-15, 2 1/2"	1.875	17000	20000	27000	36000	46000	55000	60000											
HC-30, 2"	.876	3400	4600	6400	8400	12500	16900	19000	21500	23590	24000								
HC-30, 2 1/2"	1.624	14000	17000	20900	25500	33200	40500	45500	49400	52700	55600								
HC-75, 2"	.858	2550	3150	4300	5450	7600	10400	11400	12500	13500	14250	15600	17150	18600	20500				
HC-75, 2 1/2"	1.031	5900	7700	10000	13000	18600	24200	28300	31600	34400	36800	41100	44800	48040	52300				
HC-125, 2"	.448	2300	2800	3450	4200	5450	6600	7450	8050	8600	8950	10350	11950	13400	15600	18850	21800		
HC-125, 2 1/2"	.797	4000	5300	6900	9100	13000	17100	20000	22400	24500	26300	29400	32100	34650	37600	42100	46000		
HC-175, 1 1/4"	.210	260	350	480	640	940	1190	1450	1560	1670	1750	1910	2040	2100	2300	2500	2900	3140	3240
HC-175, 1 1/2"	.210	260	350	480	640	940	119	1450	1560	1670	1750	1910	2040	2100	2300	2500	2900	3140	3240
HC-175, 2"	.375	2100	2600	3000	3500	4400	4900	5350	5800	6250	6700	7600	8600	9550	11000	13000	14750	16500	18000
HC-175, 2 1/2"	.688	2460	3350	4600	6200	9400	12800	15400	17500	19300	21000	23800	26300	28060	31600	35900	39700	43100	46200

For Kg/Hr Multiply by .454