



Series 92 Electric Actuators

Standard Features (Sizes 1-1/2" – 3")

- Brushless, capacitor-run motors
- Integral thermal overload protection with auto-reset
- Permanently lubricated gear train
- Combination Type 4X, 7 and 9 enclosure with thermally bonded powder coating/304 SS trim
- ISO bolt circle
- Two 1/2" NPT conduit ports prevent interference between control and power signals
- Declutchable manual override
- Highly visible position indicator
- 3-Layer rotary switch for dry contact indication

Options

- Extra limit switches (see page 82)
- Feedback potentiometer
- Heater and thermostat (to -40° F)
- Positioner: 4-20mA or 0-10 VDC input signal
- 4-20mA output position transmitter

AC Wiring (For 115 VAC only)

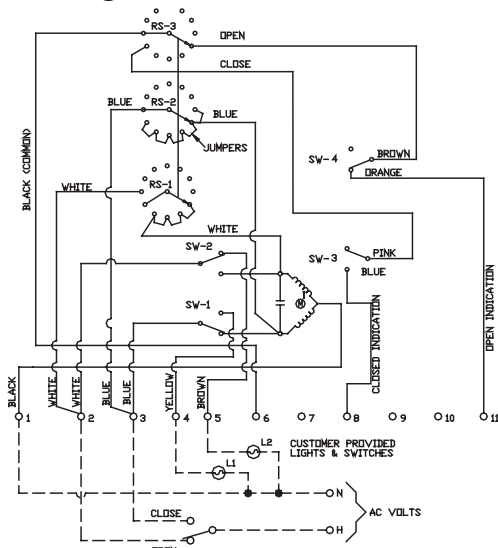

Specifications

Series 92: Motor Type – Reversing, single phase
 Model – S92 for sizes 1-1/2" – 3"
 Torque – 400 in.-lbs.
 Voltage – 120 VAC, 50/60 Hz
 Max Ambient Temp. – 150° F
 Switches – Two single pole, double throw [15 Amp rating]

SERIES 92 ON TYPE P GATE VALVE

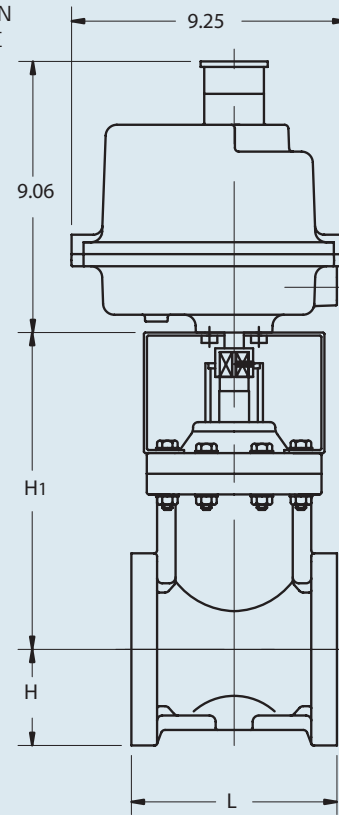

Engineering Data

ACTUATOR MODEL	VOLTAGE	DUTY CYCLE	AMP DRAW	WEIGHT
S92	120 VAC	25%	.50	10 lbs.

NOTE TO WIRING DIAGRAM:

1. IF 120 VAC MODEL IS PLC DRIVEN, OUTPUT CONTACTS OF PLC SHOULD BE RATED AT A MINIMUM OF 1.5 TIMES REQUIRED INPUT VOLTAGE OF ACTUATOR.
2. EACH ACTUATOR MUST BE POWERED THROUGH ITS OWN INDIVIDUAL SWITCH CONTACTS TO AVOID CROSS FEED.
3. MOTOR HAS A THERMAL PROTECTOR AS SHOWN BY (M) IN DIAGRAM.

Dimensions

NOMINAL SIZE		H	H ₁	L
INCHES	mm			
1 1/2	40	2.50	9.00	6.50
2	50	3.00	10.46	7.01
3	80	3.75	14.06	7.99