



## Type 57 LIS Butterfly Valve Standard Features (Sizes 3" – 8")

- Direct Replacement for metal valves conforming to ISO-5752 Short Face to Face dimensions.
- Standard model has PVC body with PP disc for superior chemical and corrosion resistance as well as elevated temperature capabilities.
- Non-wetted 316 SS stem has full engagement over the entire length of the disc and is totally isolated from the media.
- Full seat design isolates the body and stem from the media and acts as mating flange gaskets
- Integral body stops in valve body to prevent overtightening of mating flanges
- Spherical disc design for improved CV's and superior durability
- Integral locking lever handle w/21 position throttling plate
- Plasgear™ operator – Industry first composite enclosure gear-operator
- Integral ISO-5211 top mounting pad for actuation mounting
- Polypropylene stem retainer to prevent stem removal

### Options

- 316 SS lug inserts for end-of line service
- Pneumatic and electric actuators with accessories
- Alternate Disc Materials
  - (I) PVC
  - (II) CPVC
  - (III) PVDF
- Alternate Stem Materials
  - (I) Titanium
  - (II) Hastelloy
- 2" Square Operating nuts on valve stem or gear operator shaft
- Stem Extensions for above ground or buried applications
- Chain Operators
- Manual Limit Switches

### Specifications

- Sizes:** Lever: 3" – 8"  
Gear: 3" – 8"
- Models:** Wafer Style or Lug Style with 316SS lug inserts
- Operators:** Lever and Plasgear
- Bodies:** PVC
- Discs:** PVC, CPVC, PP and PVDF
- Seats:** EPDM, FKM, or Nitrile
- Seals:** Same as seating material
- Stems:** 316 stainless steel, Titanium, Hastelloy C® ‡

‡ Trademark of Cabot Corporation

### Parts List (Lever: Sizes 3" – 8")

PARTS			
NO.	DESCRIPTION	PCS.	MATERIAL
1	Body	1	PVC
1a	Lug	-	Stainless Steel 304, 316
2	Disc	1	PVC, CPVC, PP, PVDF
3	Seat	1	EPDM, FKM, NBR
6	O-Ring (C)	1	EPDM, FKM, NBR
7	Stem	1	Stainless Steel 316
8	Stem Retainer	1	PP
16	Handle	1	PP
16a	Metal Insert in Handle	1	Stainless Steel 316L
17	Handle Lever	1	PPG
18	Pin	1	PPG
19	Spring	1	Stainless Steel 304
20	Washer (A)	1	Stainless Steel 304
21	Bolt (B)	1	Stainless Steel 304
22	Locking Plate	1	PPG
23	Screw (B)	4	Stainless Steel 304
24	Cap (A)	1	PP
156	Stabilization Ring	2	Stainless Steel (SCS13)
157	Screw (F)	4	Stainless Steel 304

\*Supplied installed with Lug Style Valves only

### Caution

- Never remove valve from pipeline under pressure.
- Always wear protective gloves and goggles.

# Type 57 LIS Lever Butterfly Valves

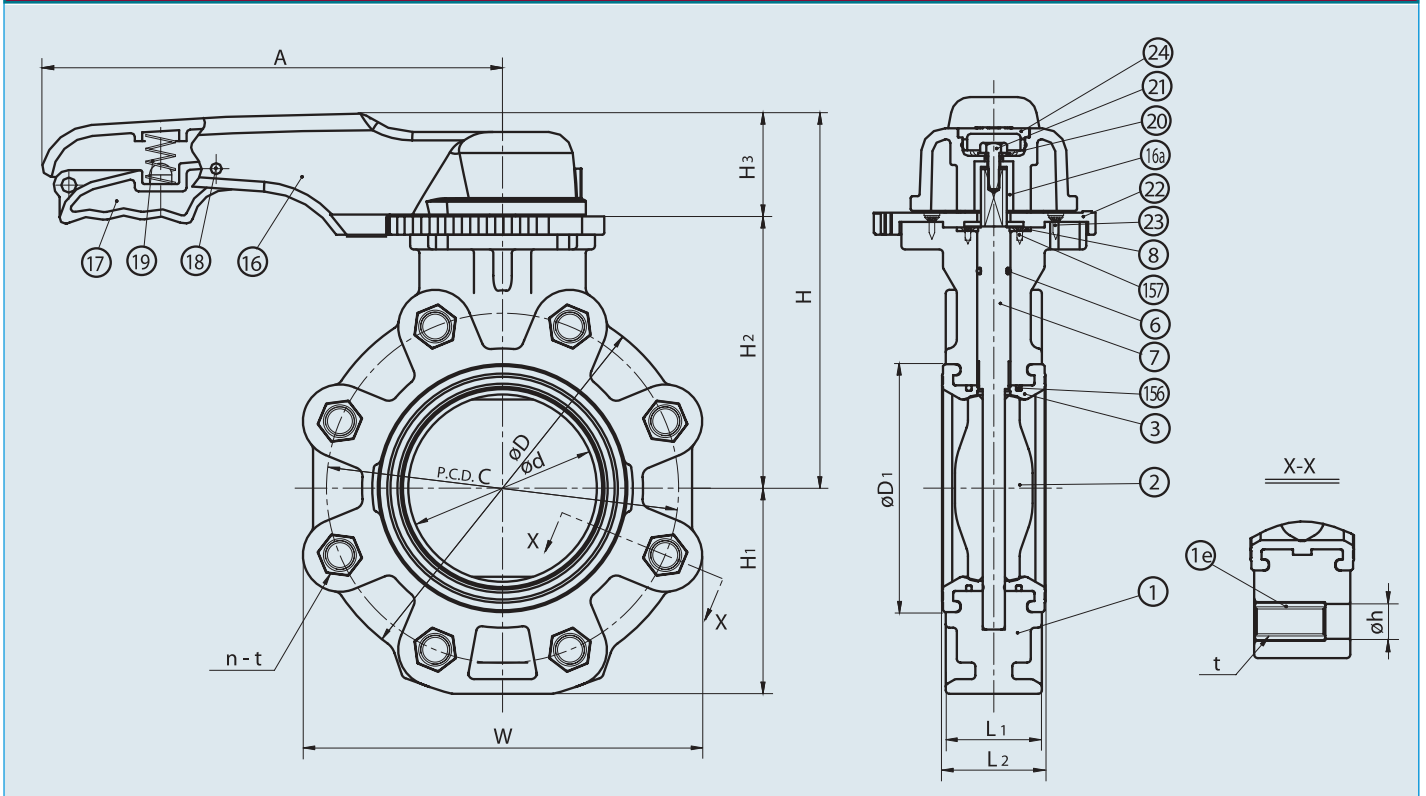

**Dimensions (Lever: Sizes 3" – 8")**

NOMINAL SIZE	ANSI CLASS 150																
	INCHES	mm	d	C	n	h	D	D1	L	L2	H	H1	H2	H3	A	W	T
3	80	3.03	6.00	4	0.75	7.28	4.13	1.73	1.81	7.52	3.82	5.31	2.20	9.84	7.09	1.26	5/8-11UNC
4	100	4.02	7.50	8	0.75	8.27	5.28	2.05	2.20	8.11	4.41	5.91	2.20	9.84	8.50	1.52	5/8-11UNC
6	150	5.91	9.50	8	0.87	10.63	7.48	2.20	2.40	9.92	5.55	7.20	2.72	12.60	10.67	1.57	3/4-10UNC
8	200	7.68	11.75	8	0.87	12.60	9.53	2.36	2.66	11.14	6.61	8.43	2.72	15.75	12.76	1.57	3/4-10UNC

## Press vs. Temp

BODY		PVC		
DISC		PP		
NOMINAL SIZE		30° F	121° F	141° F
		120° F	140° F	175° F
INCHES	mm			
3	80	150	70	30
4	100	150	45	30
6	150	150	45	30
8	200	150	40	20

## Cv Values

NOMINAL SIZE		Cv		
		(at various opening degrees)		
INCHES	mm	30°	60°	90°
3	80	18	183	300
4	100	28	287	470
6	150	66	671	1100
8	200	150	1525	2500

## Vacuum Service Wt. (LBS)

NOMINAL SIZE		VACUUM SERVICE (INCHES OF MERCURY)
INCHES	mm	
3	80	-29.92
4	100	-29.92
6	150	-29.92
8	200	-29.92

NOMINAL SIZE		LEVER OPERATED	GEAR OPERATED
INCHES	mm		
3	80	5	10
4	100	7	12
6	150	15	20
8	200	25	30

# Type 57 LIS – Gear Operated Butterfly Valve

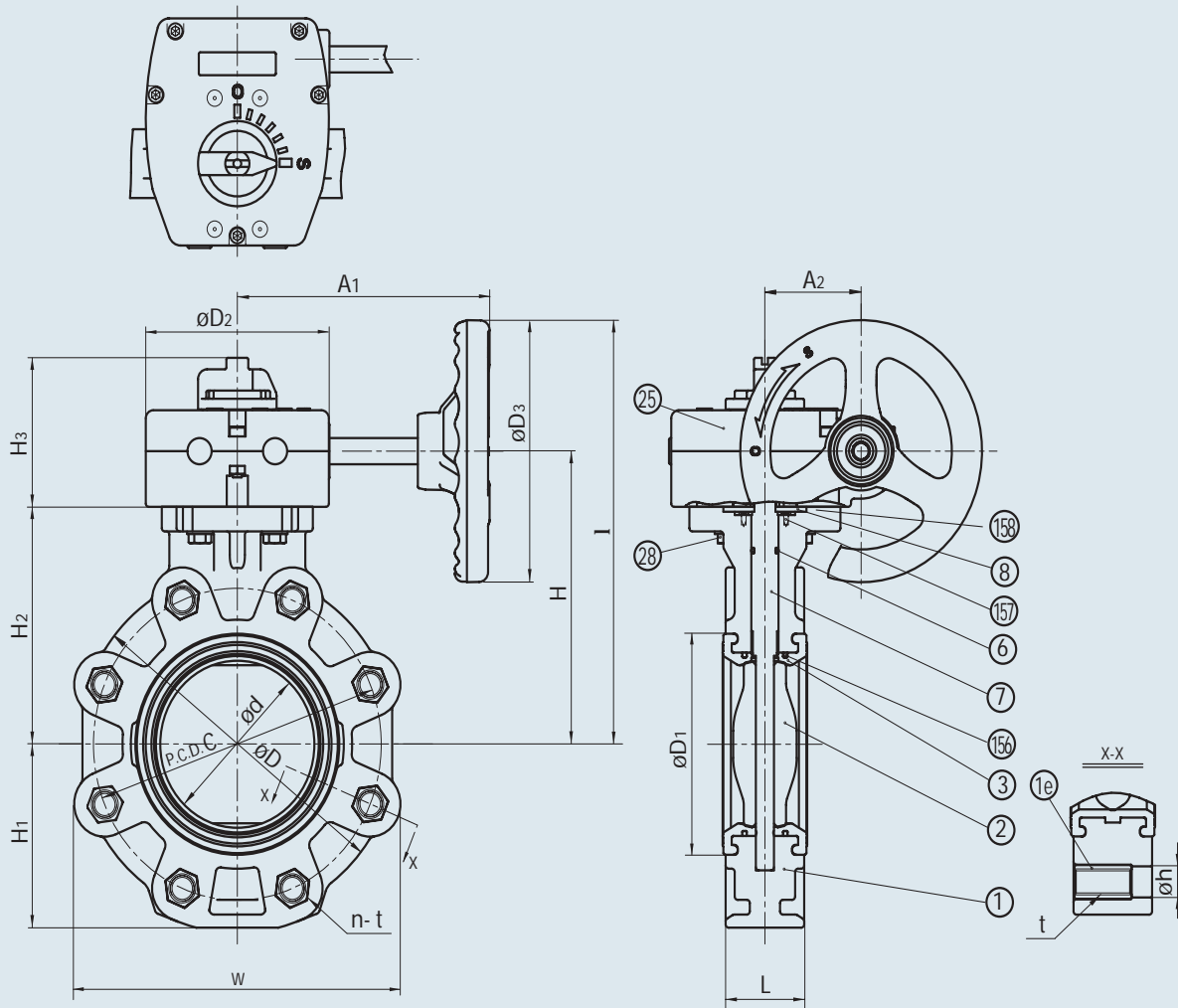

## Dimensions (Gear: Sizes 3"-8")

NOMINAL SIZE		ANSI CLASS 150																				Wheel Cycles
INCHES	mm	d	C	n	h	D	D1	D2	D3	L1	L2	H	H1	H2	H3	I	A1	A2	W	T	t	Wheel Cycles
3	80	3.03	6.00	4	0.75	7.28	4.13	4.80	6.30	1.73	1.81	6.50	3.82	5.12	3.62	9.65	6.57	2.52	7.09	1.26	5/8-11UNC	9.5
4	100	4.02	7.50	8	0.75	8.27	5.28	4.80	6.30	2.05	2.20	7.09	4.41	5.71	3.62	10.24	6.57	2.52	8.50	1.52	5/8-11UNC	9.5
6	150	5.91	9.50	8	0.87	10.63	7.48	4.80	6.30	2.20	2.40	8.27	5.55	6.89	3.62	11.42	6.57	2.52	10.67	1.57	3/4-10UNC	9.5
8	200	7.68	11.75	8	0.87	12.60	9.53	4.80	6.30	2.36	2.66	9.49	6.61	8.11	3.62	12.64	6.57	2.52	12.76	1.57	3/4-10UNC	9.5

## Parts List (Gear: 3" – 8")

PARTS			
NO.	DESCRIPTION	PCS.	MATERIAL
1	Body	1	PVC
1e	Lug	-	Stainless Steel 304, 316
2	Disc	1	PVC, PP, PVDF
3	Seat	1	EPDM, FKM, NBR
6	O-Ring (C)	1	EPDM, FKM, NBR
7	Stem	1	Stainless Steel 316
8	Stem Retainer	1	PP
25	Gear Box	1	Plasgear™
28	Bolt (C)	4	Stainless Steel 304
156	Stabilization Ring	2	Stainless Steel (SCS13)
157	Screw (F)	4	Stainless Steel 304
158	Gasket	1	EPDM

\* Supplied installed with Lug Style Valves only

## Sample Specification

All Type 57 LIS butterfly valves shall be of solid thermoplastic lined body design with only the disc and seat as wetted parts. The face to face dimension shall be in accordance to ISO-5752 Short face to face dimensions. All valves shall meet class 6 bubble tight shut-off standards. Operators shall be either molded PP lever handles with PPG trigger and 21 position throttle plate or Plasgear™ plastic enclosure gear-operators. The lever handle shall feature a molded provision for padlocking. Valves shall feature spherical design discs for improved CV's and lower seating torque. Seats or Liners shall be molded and formed around the the valve body, and provide a gasket face for mating flanges. The valve body shall include molded body stops to prevent mating flange overtightening. Valves shall be molded wafer style and accept 316 SS factory installed Lug inserts. Lug style valves shall be capable of having the downstream flange removed while maintaining full line pressure on the upstream side. Valve stems shall be 316 SS and have full engagement over the entire length of the disc. Valves shall feature molded ISO-5211 top flange bolt patterns for actuation mounting. PVC shall conform to ASTM D1784 Cell Classification [CC] 12454-A, CPVC to ASTM D1784 CC 23567A, PP to ASTM D4141 CC 0210B67272, and PVDF to ASTM D3222-91A CC Type II. All Type 57 LIS butterfly valves shall be rated to 150 psi at 70 °F and be wafer or lug style as manufactured by Asahi/America Inc.