

ASAHI/AMERICA

**Fluid-Lok™
HDPE Double
Containment
Piping System**

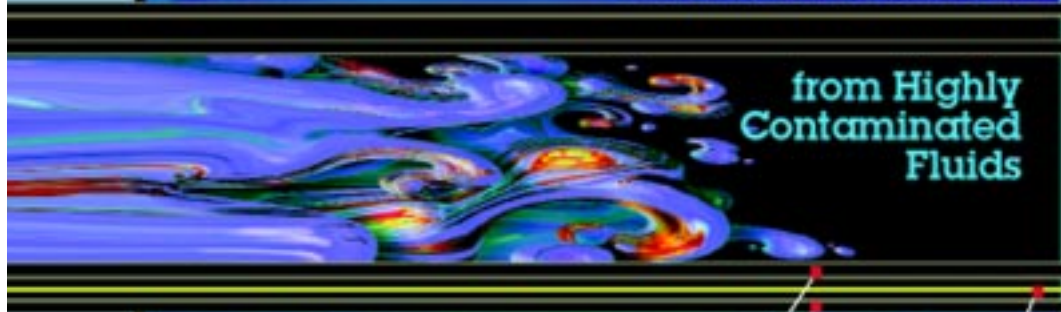

**Protecting You
and the Environment**



**from Highly
Contaminated
Fluids**



- Double Wall Construction
- Advanced Leak Detection
- Patented Dogbone® Coupling



Fluid-Lok® High Density Polyethylene Double Containment Piping Systems Provide that Extra Margin of Safety for Protecting Our Environment.



Asahi/America has been providing double containment piping systems to meet EPA standards for over 15 years. As the innovator and patent holder of many double containment specialty devices, Asahi/America is best equipped to help engineers and designers fabricate and install double containment piping systems. For the varying requirements of double containment, Asahi/America provides many different piping system options.

Engineered Design

The newest addition is the Fluid-Lok HDPE double containment piping system. Available in high density polyethylene in the widest variety of sizes and wall thickness options, Fluid-Lok provides a cost-effective piping material with sound engineering design to create a reliable HDPE double-wall system for environmental protection.

Fluid-Lok is available from 1" x 3" to 18"x 24" with larger sizes available upon request. The system is designed around centralizing the carrier pipe inside the containment piping and locking the two components together. Once inner and outer pipe and fittings are fabricated and locked together, all field welds are conducted as in a single wall piping system. Inner and outer welds are joined reliably at the same time.

The Dogbone®

At the heart of all Asahi/America's double containment piping systems is our patented Dogbone fitting, which provides

- Transition from single to double wall pipe without reducing the pressure rating
- Locking of the inner pipe to the outer pipe for proper stress control
- The means for a system to be compartmentalized in the case of a leak
- Control of thermal expansion

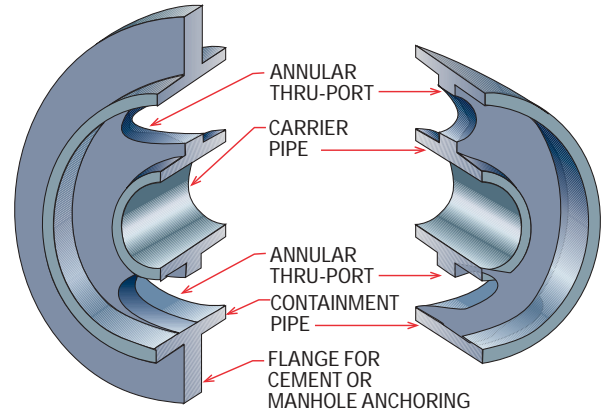

Asahi Force Transfer Coupling (L.) Dogbone (R.)

EPA Standards

To meet EPA Standard 40 CFR, Part 280, for transport of hazardous chemicals underground, a system must:

- Have double containment
- Have automated leak dection for pressurized systems
- Have outer containment able to withstand transported media for a minimum of 30 days

The Fluid-Lok system is a homogenous material inside and out, providing equal chemical resistance on the carrier and containment pipe. Fluid-Lok also has many leak detection options. Systems can be provided with continuous leak detection cable, low point sensors, or manual observation ports. No matter the requirement, Asahi/America can engineer and provide the leak detection system as well as the piping components required for your application.

Engineering Assistance

To install an entire double containment piping system is similar to installing a single wall system. Double containment piping adds a few variables to the equation: how to handle thermal expansion; where to place leak detection pull ports or low point sensors; and how to properly restrain and terminate the outer containment piping. For all of these concerns, Asahi/America's engineering staff is ready to assist and review each and every design. Assistance is readily available for fluid dynamics, stress analysis, pipe burial, pipe hanging, and chemical resistance checks for the media transported.

Custom Fabrications

Double contained systems incorporate more than pipe and fittings. With Asahi/America's extensive fabrication capabilities, custom components can also be supplied for each specific project. Asahi/America has the experience to offer:

- Thermoplastic manholes
- Double contained valve boxes
- Observation ports
- Double contained tanks
- Custom fittings and assemblies

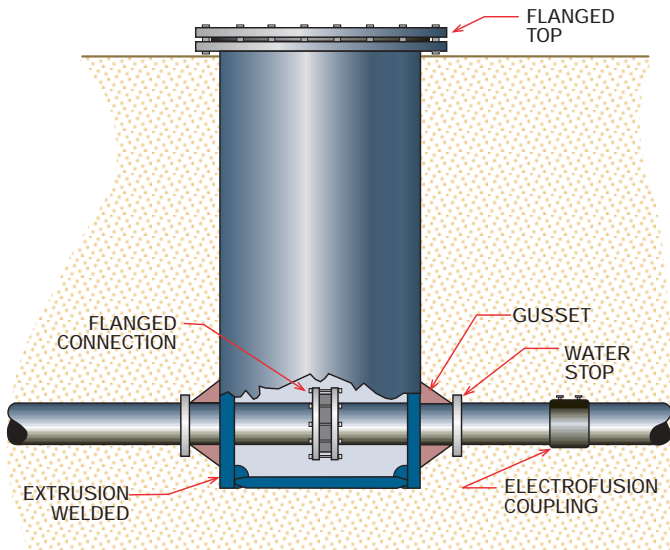

Manhole Assembly with Pipe Connections

Design and Installation

The Fluid-Lok system design consists of centralizing support disks inside the containment pipe, minimizing carrier pipe deflection and extending the life of the system.

Fittings are made from the same resin as the pipe, and they are available in a variety of configurations for pressure and drainage applications.

Systems are assembled utilizing the butt-fusion welding technique. Welding equipment, available for rental or purchase, comes in multiple styles and configurations, which our technical staff will recommend, based on the specific requirements of each project. Equipment ranges from small manual tools to much larger hydraulic-driven units for large diameter systems.

With welding comes the need for training and on-site assistance. Asahi/America's Field Support Program can furnish field technicians to provide equipment, weld training and weld certification according to established ISO standards, or they can supervise an entire installation.

In addition to weld training, technicians are available for the installation and start-up of continuous, cable or low point leak detection systems.



Fluid-Lok Pipe, Dogbone, and Centralizer

Leak Detection

Asahi/America offers two state-of-the-art leak detection systems:

- PAL-AT™: A continuous leak detection cable system that can incorporate probes and float switches
- Liquid Watch™: A flexible, modular low point system based on inline probes

The PAL-AT™ system provides many unique features:

- The ability to identify a leak within one foot of the source
- Up to 5,000 feet of monitoring on a single cable
- The ability of the cable to be dried in place, eliminating the need to repull or replace wet cable
- The ability to differentiate between a cable break and a leak
- System can be calibrated while wet spots are drying

PAL-AT™ and Liquid Watch™ are Registered Trademarks of Perma Alert.

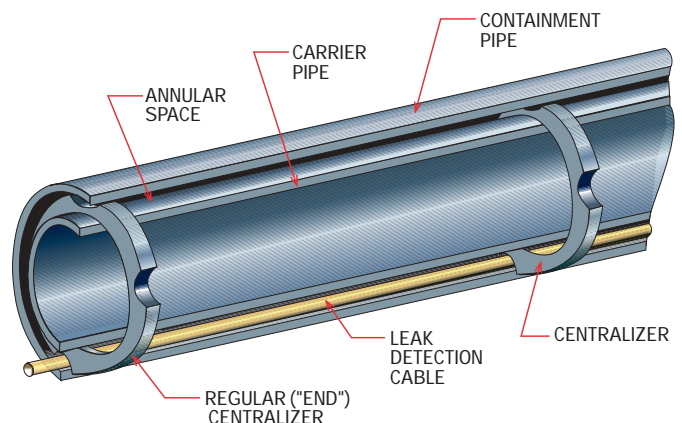

Elements of Fluid-Lok Dual Containment Pipe

ASAHI/AMERICA, INC.
35 Green Street
P.O. Box 653
Tel: 800-343-3618; 781-321-5409
Fax: 800-426-7058
Email: pipe@asahi-america.com
Website: www.asahi-america.com

