

Type 10

Pressure Regulator Series

Features

Highly Accurate Pressure Regulation

The Bellofram Type 10 Regulator controls output pressure with an accuracy of 0.1%, and has very low sensitivity to changes in supply pressure and flow.

Start-Up Stability

The Type 10 Regulator has been designed to eliminate the need for any readjustment of the regulated pressure after long "down time." At start-up, the regulated pressure will return to its output setting.

Flow Stability

The regulated pressure is held constant over substantial changes in flow due to the high-gain pneumatic servo amplifier. Particularly good from dead end to 20 cubic meters per hour (12 SCFM).

Automatic High Downstream Relief Capacity

An integral relief valve provides for exhaust flow whenever the regulated pressure is reset to a lower value. The exceptionally large capacity of this relief valve assures immediate response when the downstream regulated pressure must be reduced under dead-end conditions.

Pressure Stability

A high performance servo-operated control mechanism is utilized in the regulator. The pressure supplied to the pneumatic servo amplifier is reduced and held constant.

Locking Capability

The standard Type 10 regulator has a locking nut which, when tightened, prevents inadvertent adjustment of pressure.

Temperature Stability

Shifts in the regulated pressure over wide ambient temperature variations are minimized by the use of a measuring capsule made of specially selected stainless steel alloys.

Proven Reliability

Thousands of Type 10 Regulators are in the field. Proof of the accuracy of the regulator is reflected by its use in most air gauging systems and other precision pressure control applications.

Mounting

The unit may be installed in any position. It can be panel mounted or supported by in-line plumbing.

Applications

Industrial processes, inspection procedures, control and analytical instrumentation require precise regulation of air pressure in pipes and vessels. Maintaining constant pressures in these applications is usually complicated by the presence of numerous disturbances, such as changes in supply pressure, flow, and ambient temperature, that tend to upset prevailing conditions.

Bellofram Pressure Regulators provide accuracy, precision control, and maximum stability under the most adverse operating conditions.

Type 10 Pressure Regulator Applications

- Gas Mixing
- Valve Operators
- Gate Actuators
- Positioner Signal
- Calibration Stands
- Air Hoists
- Air Gauging
- Cylinder Loading
- Force Balance Hoists
- Disc and Shoe Air Brakes
- Clamp Units
- Web Tensioning
- Press Units
- Roll Loading

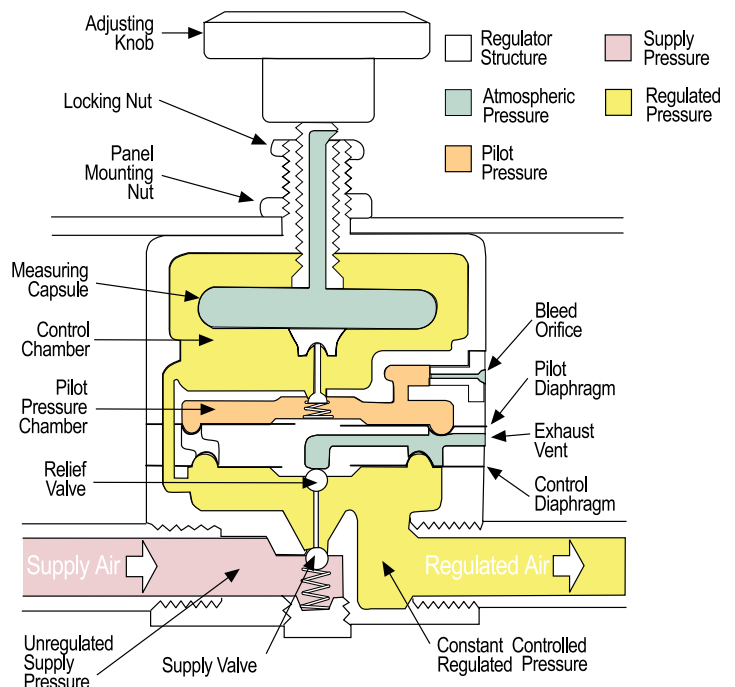

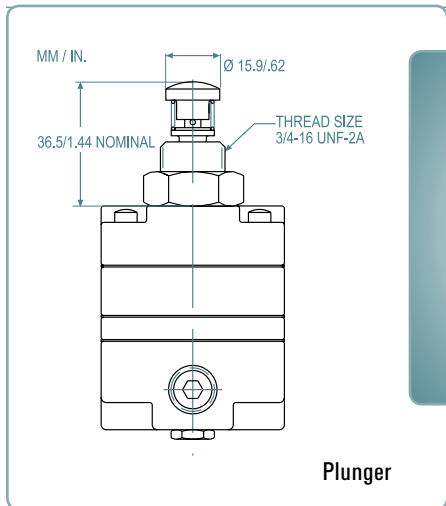

Plunger

Type 10PI Plunger Operated Regulator

This reliable plunger operated regulator provides unmatched accuracy and repeatability. Regulated pressure is changed by direct linear actuation of the plunger instead of turning a knob.

| Plunger Travel | | | |
|----------------|-------|-----------------|------|
| Pressure Range | | Plunger Travel* | |
| BAR | psig | mm | inch |
| 0.1-1.7 | 2-25 | 1.9 | .075 |
| 0.1-4.1 | 2-60 | 2.3 | .090 |
| 0.1-8.3 | 2-120 | 2.5 | .100 |

*±10% manufacturing tolerance

Return Spring

0.4 in. (10mm) nominal return height; 7 oz. (200g) approximate preload force; 7.5 lb./in. (135g/mm) approximate spring rate, between 0.4 in. (10mm) and 0.24 in. (6.5mm) compressed height.

Plunger Knob Material: Steel

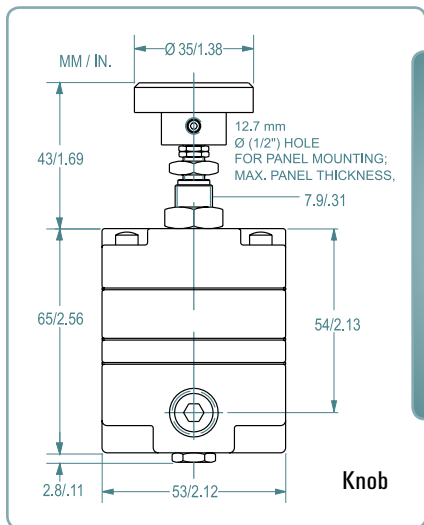

Knob

The basic Type 10 Regulator is offered with a choice of three port sizes and three output ranges.

Type 10HR & 10EXHR High Relief Regulators

Similar in proven accuracy and rugged construction to other Type 10 Regulators, these units provide extra fast "blowdown" for very rapid release of down stream pressure. The extra relief feature makes these regulators suitable for cylinder return stroke actuation, air hoists, and similar applications requiring fast exhaust.

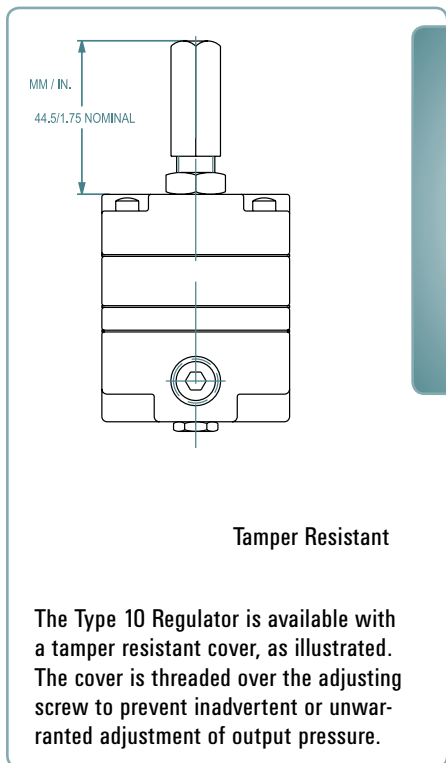

Tamper Resistant

The Type 10 Regulator is available with a tamper resistant cover, as illustrated. The cover is threaded over the adjusting screw to prevent inadvertent or unwarranted adjustment of output pressure.

Type 10LR Low Range Regulator

The main feature of the Type 10LR is its low-range pressure characteristic. It operates on a maximum of 50 psig / 3.4 BAR supply pressure and offers an output pressure range of 0.5 psig / 0.03 BAR to 25 psig / 1.7 BAR

The Type 10 Regulator is also available with bottom ports, (Type 10BM) consult factory.

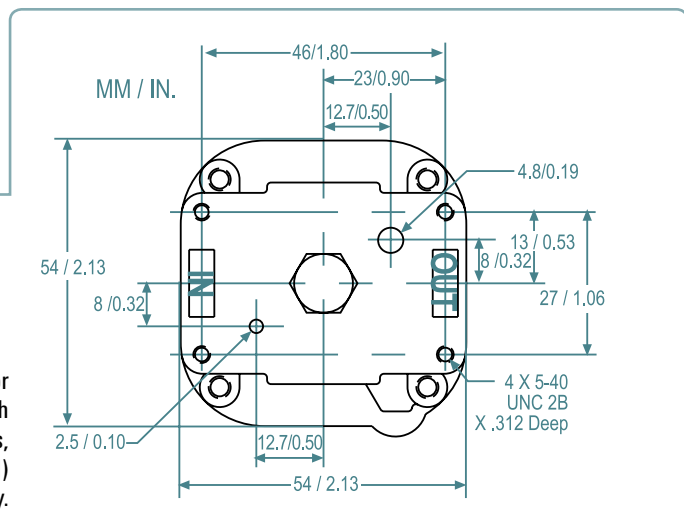

| | Type 10LR | Type 10 / 10PL | Type 10 BM | Type 10HR | Type 10 EXHR | Type 10 HF | Type 10 Motorized |
|--|---|---|---|---|---|---|---|
| Maximum Supply Pressure | 50 psig / 3.4 BAR | 150 psig / 10.3 BAR | 150 psig / 10.3 BAR | 150 psig / 10.3 BAR | 150 psig / 10.3 BAR | 50 psig / 3.4 BAR | 150 psig / 10.3 BAR |
| Pressure Ranges | .5-25 psig 0.03 - 1.7 BAR | 2-25, 2-60, 2-120 psig 0.14-1.7, 0.14-4.1, 0.14-8.3 BAR | 2-25, 2-60, 2-120 psig 0.14-1.7, 0.14-4.1, 0.14-8.3 BAR | 2-120 psig 0.14-8.3 BAR | 2-120 psig 0.14-8.3 BAR | 2-25 psig 0.14-1.7 BAR | 0.5-25, 2-25, 2-60, 2-120 psig 0.03-1.7, 0.14-1.7, 0.14-4.1, 0.14-4.1, 0.14-8.3 BAR |
| Port Sizes | 1/4 | 1/8, 1/4, 3/8 | N/A | 1/8, 1/4, 3/8 | 1/8, 1/4, 3/8 | 3/8 | 1/8, 1/4, 3/8 |
| Effect of Supply Pressure Variation on Outlet Pressure | 0.005 psig / 0.3 mBAR per 25 psig / 1.7 BAR change | 0.005 psig / 0.3 mBAR per 25 psig / 1.7 BAR change | 0.005 psig / 0.3 mBAR per 25 psig / 1.7 BAR change | 0.005 psig / 0.3 mBAR per 25 psig / 1.7 BAR change | 0.005 psig / 0.3 mBAR per 25 psig / 1.7 BAR change | 0.005 psig / 0.3 mBAR per 25 psig / 1.7 BAR change | 0.005 psig / 0.3 mBAR per 25 psig / 1.7 BAR change |
| Sensitivity | 1/8" / 3.2mm of water | 1/8" / 3.2mm of water | 1/8" / 3.2mm of water | 1/8" / 3.2mm of water | 1/8" / 3.2mm of water | 1/8" / 3.2mm of water | 1/8" / 3.2mm of water |
| Bleed Rate | 4.8 scfh / 2.3 LPM | 4.8 scfh / 2.3 LPM | 4.8 scfh / 2.3 LPM | 4.8 scfh / 2.3 LPM | 4.8 scfh / 2.3 LPM | 4.8 scfh / 2.3 LPM | 4.8 scfh / 2.3 LPM |
| Forward Flow Capacity | 4 scfm / 113 LPM | 14 scfm / 396 LPM | 3 scfm / 85 LPM | 14 scfm / 396 LPM | 14 scfm / 396 LPM | 40 scfm / 1132 LPM | 10 scfm / 283 LPM |
| Exhaust Capacity @ 5 psig (0.4 BAR) above setpoint | 2 scfm / 56 LPM | 2 scfm / 56 LPM | 2 scfm / 56 LPM | 10 scfm / 283 LPM | 15 scfm / 424 LPM | 2 scfm / 56 LPM | 2 scfm / 56 LPM |
| Temperature Range | -20 to 160 °F -29 to 71 °C | -20 to 160 °F -29 to 71 °C | -20 to 160 °F -29 to 71 °C | -20 to 160 °F -29 to 71 °C | -20 to 160 °F -29 to 71 °C | -20 to 160 °F -29 to 71 °C | 0 to 140 °F -18 to 60 °C |
| Effect of Changes in Flow on Regulated Pressure | N/A | 0.25 psig / 0.01 BAR per 10 scfm / 283 LPM | N/A | 0.25 psig / 0.01 BAR per 10 scfm / 283 LPM | 0.25 psig / 0.01 BAR per 10 scfm / 283 LPM | 0.25 psig / 0.01 BAR per 10 scfm / 283 LPM | 0.25 psig / 0.01 BAR per 10 scfm / 283 LPM |

Effect of Changes in Flow on Regulated Pressure

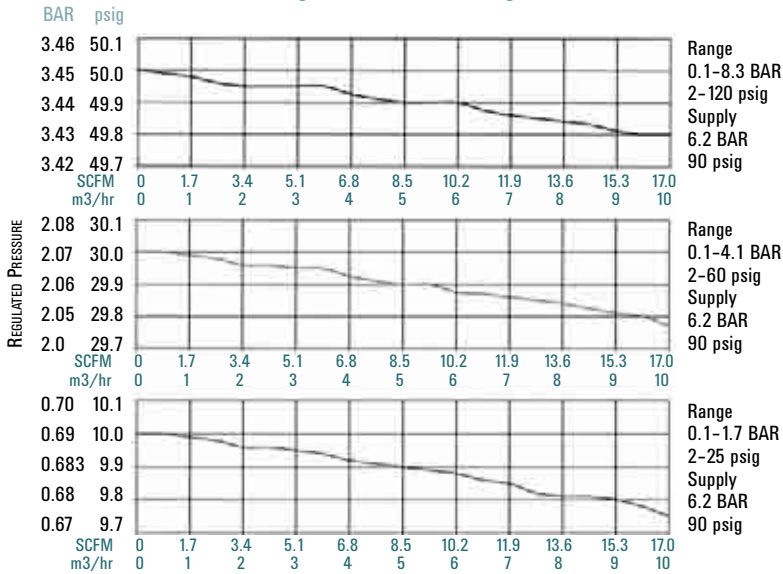

Effect of Upstream Pressure Variations on Regulated Pressure

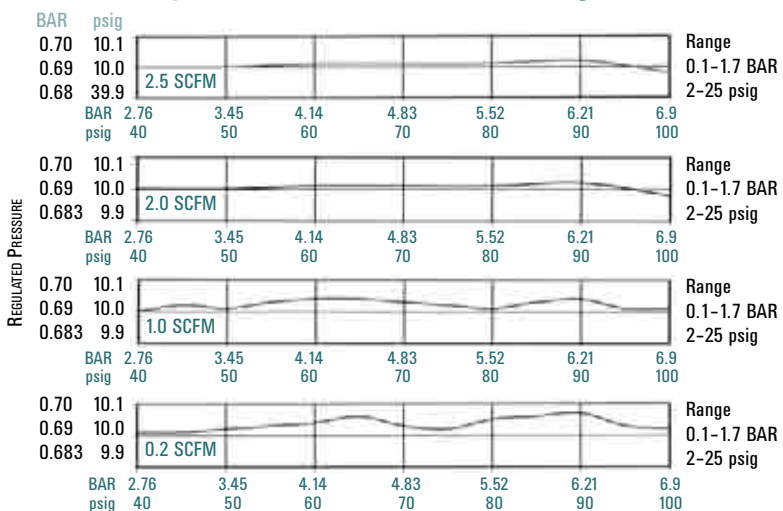

Manual Type 10 Ordering Information

| Type | Part Number | Port Size NPT | Control Range | |
|--------|-------------|------------------|---------------|--------|
| | | | BAR | psig |
| 10 | 960-001-000 | 1/8 | 0.1-1.7 | 2-25 |
| | 960-003-000 | 1/4 | 0.1-1.7 | 2-25 |
| | 960-005-000 | 3/8 | 0.1-1.7 | 2-25 |
| 10 | 960-007-000 | 1/8 | 0.1-4.1 | 2-60 |
| | 960-009-000 | 1/4 | 0.1-4.1 | 2-60 |
| | 960-011-000 | 3/8 | 0.1-4.1 | 2-60 |
| 10 | 960-013-000 | 1/8 | 0.1-8.3 | 2-120 |
| | 960-015-000 | 1/4 | 0.1-8.3 | 2-120 |
| | 960-017-000 | 3/8 | 0.1-8.3 | 2-120 |
| 10BM | 960-126-000 | | 0.1-1.7 | 2-25 |
| | 960-127-000 | N/A | 0.1-4.1 | 2-60 |
| | 960-128-000 | | 0.1-8.3 | 2-120 |
| 10HR | 960-028-000 | 1/8 | 0.1-8.3 | 2-120 |
| | 960-029-000 | 1/4 | 0.1-8.3 | 2-120 |
| | 960-030-000 | 3/8 | 0.1-8.3 | 2-120 |
| 10EXHR | 960-072-000 | 1/8 | 0.1-8.3 | 2-120 |
| | 960-073-000 | 1/4 | 0.1-8.3 | 2-120 |
| | 960-074-000 | 3/8 | 0.1-8.3 | 2-120 |
| 10PL | 960-019-000 | 1/8 | 0.1-1.7 | 2-25 |
| | 960-020-000 | 1/4 | 0.1-1.7 | 2-25 |
| | 960-021-000 | 3/8 | 0.1-1.7 | 2-25 |
| 10PL | 960-022-000 | 1/8 | 0.1-4.1 | 2-60 |
| | 960-023-000 | 1/4 | 0.1-4.1 | 2-60 |
| | 960-024-000 | 3/8 | 0.1-4.1 | 2-60 |
| 10PL | 960-025-000 | 1/8 | 0.1-8.3 | 2-120 |
| | 960-026-000 | 1/4 | 0.1-8.3 | 2-120 |
| | 960-027-000 | 3/8 | 0.1-8.3 | 2-120 |
| 10LR | 960-053-000 | 1/4 | 0.03-1.7 | 0.5-25 |

Type 10 Motorized Pressure Regulators

Bellofram's high precision Type 10 pressure regulator – a servo balanced system in which the main valve is operated by a pilot valve – is also available in a motorized configuration. This combination is particularly attractive because it offers low power requirements (2 rpm/4 watts; 6 rpm/6 watts) with extremely high accuracy.



Regulator-Motor Specifications

| Pressure Range | | Approximate Time to Cover Full Range (seconds) | |
|----------------|-------|--|-------|
| BAR | psig | 2 rpm | 6 rpm |
| 0.1-1.7 | 2-25 | 75 | 25 |
| 0.1-4.1 | 2-60 | 90 | 30 |
| 0.1-8.3 | 2-120 | 150 | 50 |

*±10% manufacturing tolerance

Applications

The motorized Type 10 pressure regulator can be used for any application where electric control of a pneumatic system is desired. It is often used for remote pressure control and for ventilation systems. It can also be easily integrated into open or closed loop process control systems and may be used with programmable controllers.

Features

- Mountable at any angle
- In the event of power failure, the pneumatic output remains constant at last setting
- Low electrical power requirements
- Adjustable mechanical stop limits maximum output pressure
- No electrical power is required when operating at constant output pressure
- No pre-regulation of supply pressure required
- Built-in overload slip clutch prevents damage to gear train at end of travel, eliminating the need for limit switches in most applications.

Construction

The regulator and motor are mounted to a bracket and connected to each other through a flexible coupling. The assembly can be mounted through holes in the bracket.

Motor Specifications

Reversible, synchronous motor with gear drive and slip clutch.

Operating Voltage 110VAC, 24VAC, 24VDC or 220VAC.

Frequency

60 Hz, Except 220 VAC model is 50 Hz.

Power Consumption (maximum)

2 rpm/4 watts, 6 rpm/6 watts.

Speeds Available

2 and 6 rpm.

Torque

Approx. 8 in. oz.

Typical Installation

Control Circuit Diagram

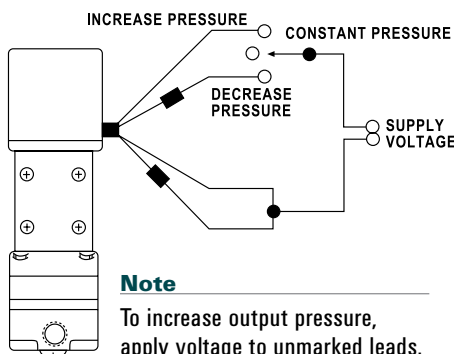

Note

To increase output pressure, apply voltage to unmarked leads. To decrease output pressure, apply voltage to marked leads.

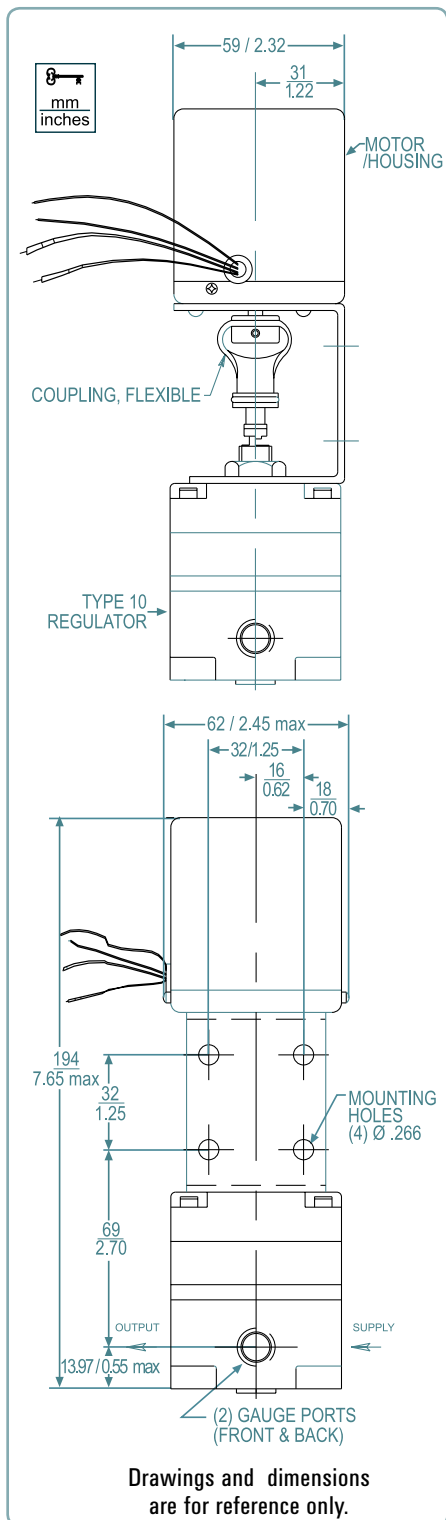

Motorized Type 10 Ordering Information

9 6 0 - 1 8 0 -

| | ↑ | ↑ | ↑ | Motor Specifications |
|----------|---|---|---|---|
| 1 | | | | 2 RPM 110 VAC 4 WATTS 60 Hz |
| 2 | | | | 6 RPM 110 VAC 6 WATTS 60 Hz |
| 3 | | | | 6 RPM 220 VAC 6 WATTS 50 Hz |
| 4 | | | | 2 RPM 24 VAC 4 WATTS 60 Hz |
| 5 | | | | 6 RPM 24 VAC 6 WATTS 60 Hz |
| 6 | | | | 6 RPM 24 VDC |
| | | | | Pressure Range |
| 1 | | | | 2-25 psig / 0.1-1.7 BAR |
| 2 | | | | 2-60 psig / 0.1-4.1 BAR |
| 3 | | | | 2-120 psig / 0.1-8.3 BAR |
| 4 | | | | L. R. Model, 0.5-25 psig / 0.03-1.7 BAR |
| 5 | | | | H.R. Model, 2-120 PSI / 0.1-8.3 BAR |
| | | | | Port Size |
| 1 | | | | 1/8 NPT |
| 2 | | | | 1/4 NPT |
| 3 | | | | 3/8 NPT |