

Control valve - 3-way with flanges (3-way mixing valve / 3-way diverting valve)
DN 200 and 250

ARI-STEVI® 423 / 463

Electric actuator ARI-PREMIO

- Enclosure IP 65
- 2 torque switches
- Handwheel
- Additional devices available, e.g. potentiometer

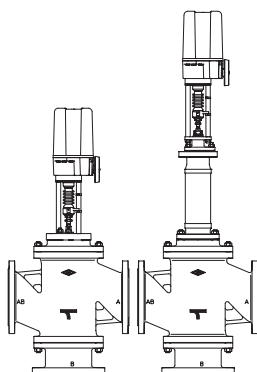

Page 2

ARI-STEVI® 423 / 463

Electric actuator AUMA SAR

- Electric multiturn actuator, capable of high closing pressures
- Enclosure IP 67
- 2 torque switches
- 2 travel switches
- Handwheel
- Overheating protection for motor as standard
- Additional devices available, e.g. potentiometer
- Explosion proof version available

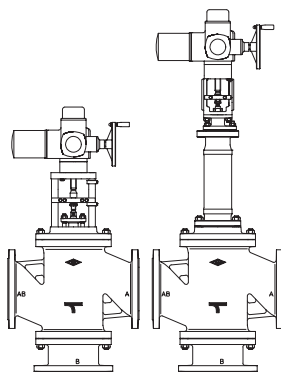

Page 6

ARI-STEVI® 423 / 463

Pneumatic actuator ARI-DP

- Reversible pneumatic actuator
- Actuator with rolling diaphragm
- Air supply pressure max. 6 bar
- Stem protection by bellow
- Maintenance-free O-ring sealing
- Assembly of additional devices acc. to DIN IEC 60534-6

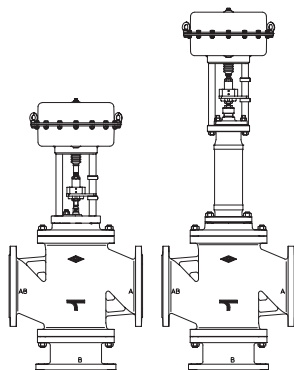

Page 10

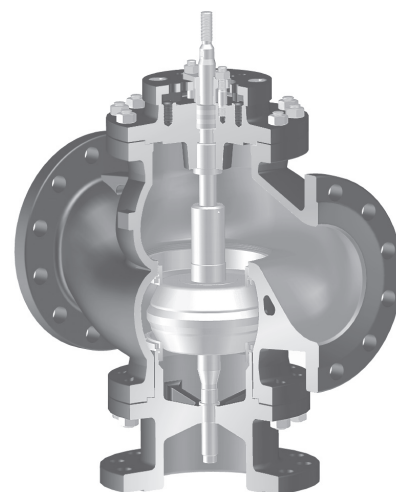

Fig. 423

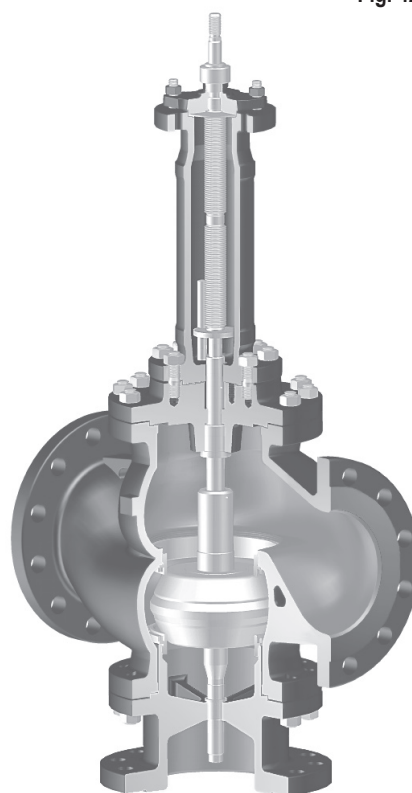

Fig. 463

Features:

- Precision guided stem
- Burnished stem
- Tapered seat ring
- Replaceable seat and plug
- Screwed seat ring
- Reducible kvs-values
- Rangeability 30 : 1
- Guided plug
- Two-ply bellows seal as standard
- Travel indicator

Control valve in 3-way-form with electric actuator ARI-PREMIO (3-way mixing valve / 3-way diverting valve)

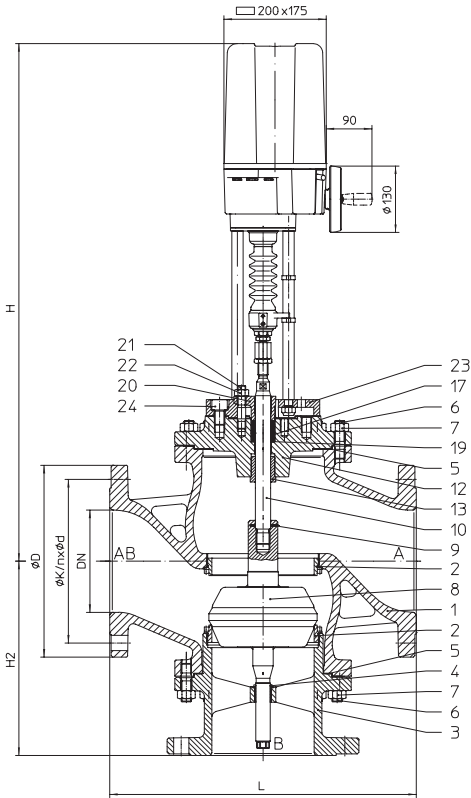

Fig. 423

Figure	Nominal pressure	Material	Nominal diameter
12.423 / 12.463	PN16	EN-JL1040	DN200-250
22.423 / 22.463	PN16	EN-JS1049	DN200-250
34.423 / 34.463	PN25	1.0619+N	DN200-250
35.423 / 35.463	PN40	1.0619+N	DN200-250

Other materials and versions on request.

Stem sealing

Fig. 423: • PTFE-packing -10°C to +250°C

• Pure graphite-packing -10°C to +450°C

Fig. 463: • Stainless steel bellows seal with safety stuffing box -60°C to +450°C

Plug design

• Mixing plug: parabolic plug / parabolic plug

• Diverting plug: parabolic plug / V-port plug

Guiding

• Mixing plug: double guiding

• Diverting plug: stem and port guiding

Flow characteristic

• linear

Rangeability

• 30 : 1

Shut off class (Seat / plug leakage classes)

• Metal seat - Leakage class IV acc. to DIN EN 1349 or IEC 60534-4

Closing pressures refer to page 4.

Technical data for actuator refer to data sheet.

Selection of possible applications

Industrial installations, processing technology, plant manufacturing, etc.
(other applications on request)

Selection of possible flow media

Fig. 423: Cooling water, cooling brine, warm water, hot water, steam, gas, etc.

Fig. 463: Refrigerant, cooling water, warm water, hot water, thermal oil, steam, gas, etc.

(other flow media on request)

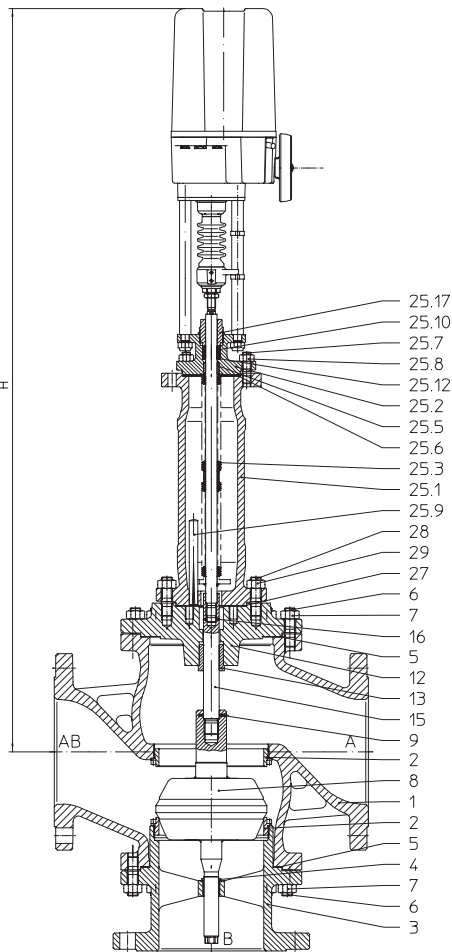
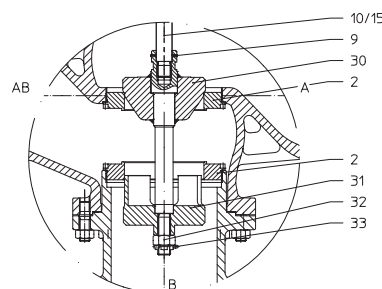

Fig. 463



Diverting construction

(Further information refer to page 16)

Dimensions and weights

DN		200	250	
L	(mm)	600	730	
H2	(mm)	380	440	
Fig. 423	H	(mm)	841	
	ARI-PREMIO 5 kN	PN16	(kg)	205
		PN25/40	(kg)	222
	H	(mm)	1013	1073
	ARI-PREMIO 12 kN	PN16	(kg)	209
		PN25/40	(kg)	226
Fig. 463	H	(mm)	1263	
	ARI-PREMIO 5 kN	PN16	(kg)	208
		PN25/40	(kg)	235
	H	(mm)	1435	1495
	ARI-PREMIO 12 kN	PN16	(kg)	212
		PN25/40	(kg)	239

Standard-flange dimensions refer to page 15.

Face-to-face dimension FTF series 1 according to DIN EN 558

Parts

Pos.	Description	Fig. 12.423 Fig. 12.463	Fig. 22.423 Fig. 22.463	Fig. 34.423 / Fig. 35.463 Fig. 34.423 / Fig. 35.463
1	Body	EN-GJL-250, EN-JL1040	EN-GJS-400-18U-LT, EN-JS1049	GP240GH+N, 1.0619+N
2	Seat ring *	X20Cr13+QT, 1.4021+QT		
3	Bottom flange	EN-GJS-400-18U-LT, EN-JS1049		GP240GH+N, 1.0619+N
4	Guide bushing	X20Cr13+QT, 1.4021+QT		
5	Gasket *	Pure graphite (CrNi laminated with graphite)		
6	Studs	25CrMo4, 1.7218		
7	Hexagon nut	C35E, 1.1181		
8	Plug *	X20Cr13+QT, 1.4021+QT		
9	Straight pin *	56Si7, 1.5026		
10	Stem *	X20Cr13+QT, 1.4021+QT		
12	Stuffing box housing	EN-GJS-400-18U-LT, EN-JS1049		GP240GH+N, 1.0619+N
13	Guide bushing	X20Cr13+QT, 1.4021+QT (hardened)		
15	Stem adapter *	X20Cr13+QT, 1.4021+QT		
16	Straight pin *	56Si7, 1.5026		
17	Packing ring *	PTFE or Pure graphite		
19	Washer *	X5CrNi18-10, 1.4301		
20	Packing box flange	EN-GJS-400-18U-LT, EN-JS1049		
21	Studs	25CrMo4, 1.7218		
22	Hexagon nut	C35E, 1.1181		
23	Adapter flange	EN-GJS-400-18U-LT, EN-JS1049		
24	Hexagon socket head screw	8.8 - A2B		
25.1	Bellows housing	EN-GJS-400-18U-LT, EN-JS1049		GP240GH+N, 1.0619+N
25.2	Mounting bonnet	EN-GJS-400-18U-LT, EN-JS1049		GP240GH+N, 1.0619+N
25.3	Stem- / Bellows unit *	X20Cr13+QT, 1.4021+QT / X6CrNiTi18-10, 1.4541		
25.5	Guide bushing	X20Cr13+QT, 1.4021+QT (hardened)		
25.6	Gasket *	Pure graphite (CrNi laminated with graphite)		
25.7	Studs	25CrMo4, 1.7218		
25.8	Hexagon nuts	C35E, 1.1181		
25.9	Straight pin	St		
25.10	Packing ring *	Pure graphite		
25.12	Washer *	X5CrNi18-10, 1.4301		
25.13	Stuffing box housing	GP240GH+N, 1.0619+N		
25.15	Packing follower *	X20Cr13+QT, 1.4021+QT		
25.16	Sleeve nut *	X8CrNiS18-9, 1.4305		
20.17	Screw joint *	X8CrNiS18-9, 1.4305		
27	Gasket *	Pure graphite (CrNi laminated with graphite)		
28	Studs	25CrMo4, 1.7218		
29	Hexagon nut	C35E, 1.1181		
30	Plug *	X20Cr13+QT, 1.4021+QT		
31	Plug *	X20Cr13+QT, 1.4021+QT		
32	Castle nut *	C35E, 1.1181		
33	Cotter pin	A4		

* Spare parts

Information / restriction of technical rules to be observed!

ARI-Valves of EN-JL1040 are not allowed to be operated in systems acc. to TRD 110.

A production allowance acc. to TRB 801 No. 45 exists (acc. to TRB 801 No. 45 EN-JL1040 is not allowed.)

The engineer, designing a system or a plant, is responsible for the selection of the correct valve.

max. permissible closing pressures for both seat positions on flow-to-open P2 = 0
 Observe restrictions by Pressure-temperature-ratings, refer to page 15.

Mixing function AB  A	DN		200		250		
	Standard Kvs-values	Seat-Ø A/B (mm)			200		250
Kvs-value				630		1000	
Travel (mm)				65		65	
Reduced Kvs-values		Seat-Ø A/B (mm)	150		200		
		Kvs-value	400		630		
		Travel (mm)	50		65		
Max. differential pressure drop (bar)			10	10	10	10	
Actuator ¹⁾ ARI-PREMIO 5 kN	Closing pressure (bar)	II. / III.	1,8				
	Operating time ²⁾ (s) (Op. speed 0,38 mm/s)		132				
Actuator ¹⁾ ARI-PREMIO 12 kN	Closing pressure (bar)	II. / III.	5,7	3,1	3,1	1,9	
	Operating time ²⁾ (s) (Op. speed 0,38 mm/s)		132	171	171		
Actuator ¹⁾ ARI-PREMIO 15 kN	Closing pressure (bar)	II. / III.	7,4	4	4	2,5	
	Operating time ²⁾ (s) (Op. speed 0,38 mm/s)		132	171	171		
II. Fig. 423: PTFE- / pure graphite-packing;			III. Fig. 463: Bellows seal				

Diverting function AB  A	DN		200		250		
	Standard Kvs-values	Seat-Ø A/B (mm)			150		180
Kvs-value				355		560	
Travel (mm)				50		65	
Reduced Kvs-values		Seat-Ø A/B (mm)	115		150		
		Kvs-value	212		355		
		Travel (mm)	50		50		
Max. differential pressure drop (bar)			10	10	10	10	
Actuator ¹⁾ ARI-PREMIO 5 kN	Closing pressure (bar)	II. / III.	3,3	1,8	1,8		
	Operating time ²⁾ (s) (Op. speed 0,38 mm/s)		132		132		
Actuator ¹⁾ ARI-PREMIO 12 kN	Closing pressure (bar)	II. / III.	10	5,7	5,7	3,9	
	Operating time ²⁾ (s) (Op. speed 0,38 mm/s)		132		132	171	
Actuator ¹⁾ ARI-PREMIO 15 kN	Closing pressure (bar)	II. / III.	12,8	7,4	7,4	5,1	
	Operating time ²⁾ (s) (Op. speed 0,38 mm/s)		132		132	171	
II. Fig. 423: PTFE- / pure graphite-packing;			III. Fig. 463: Bellows seal				

¹⁾ Motor voltage: 230V 50Hz 1~ (standard)
 Other voltages: 24V 50Hz 1~; 24V =; 110V 50/60Hz 1~; 230V 60Hz 1~; 400V 50Hz 3~; 440V 60Hz 3~
 Technical data for actuator refer to data sheet ARI-PREMIO.

²⁾ Indicated operating times with 50Hz.

Control valve in 3-way-form with electric actuator AUMA (3-way mixing valve / 3-way diverting valve)

Figure	Nominal pressure	Material	Nominal diameter
12.423 / 12.463	PN16	EN-JL1040	DN200-250
22.423 / 22.463	PN16	EN-JS1049	DN200-250
34.423 / 34.463	PN25	1.0619+N	DN200-250
35.423 / 35.463	PN40	1.0619+N	DN200-250

Other materials and versions on request.			
Stem sealing			
Fig. 423: • PTFE-packing -10°C to +250°C • Pure graphite-packing -10°C to +450°C			
Fig. 463: • Stainless steel bellows seal with safety stuffing box -60°C to +450°C			
Plug design			
• Mixing plug: parabolic plug / parabolic plug • Diverting plug: parabolic plug / V-port plug			
Guiding			
• Mixing plug: double guiding • Diverting plug: stem and port guiding			
Flow characteristic			
• linear			
Rangeability			
• 30 : 1			
Shut off class (Seat / plug leakage classes)			
• Metal seat - Leakage class IV acc. to DIN EN 1349 or IEC 60534-4			
Closing pressures refer to page 8.			
Technical data for actuator refer to data sheet.			

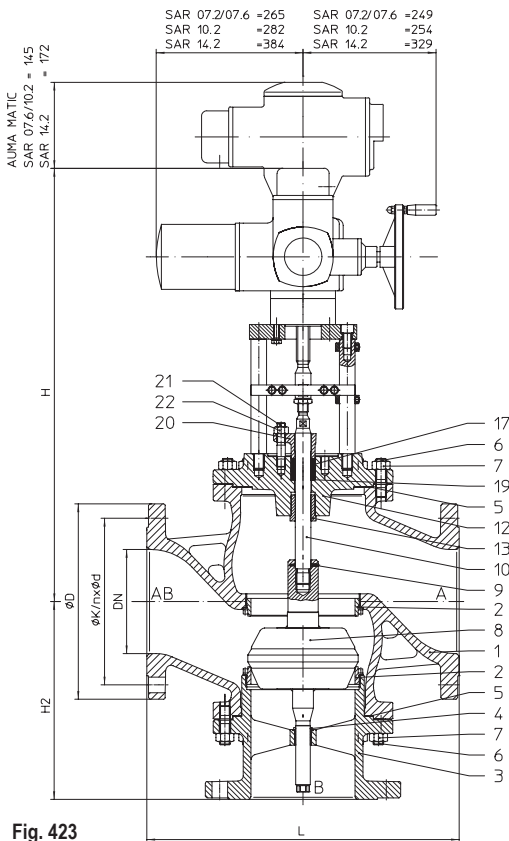

Fig. 423

Selection of possible applications

Industrial installations, processing technology, plant manufacturing, etc.
(other applications on request)

Selection of possible flow media

Fig. 423: Cooling water, cooling brine, warm water, hot water, steam, gas, etc.
Fig. 463: Refrigerant, cooling water, warm water, hot water, thermal oil, steam, gas, etc.
(other flow media on request)

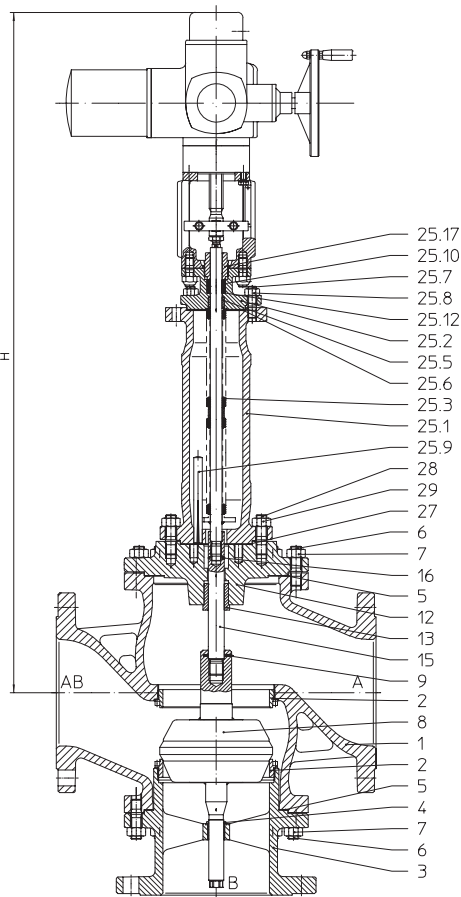
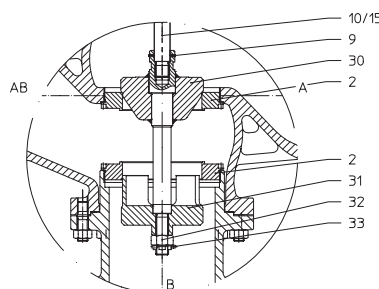

Fig. 463



Diverting construction

(Further information refer to page 16)

Dimensions and weights

DN			200	250	
L		(mm)	600	730	
H2		(mm)	380	440	
Fig. 423	H	(mm)	845	905	
	AUMA SAR 07.6	PN16	(kg)	231	376
		PN25/40	(kg)	247	388
	H	(mm)	857	917	
	AUMA SAR 10.2	PN16	(kg)	234	380
		PN25/40	(kg)	251	392
	H	(mm)	932	992	
	AUMA SAR 14.2	PN16	(kg)	264	410
PN25/40		(kg)	281	422	
Fig. 463	H	(mm)	1290	1350	
	AUMA SAR 07.6	PN16	(kg)	229	406
		PN25/40	(kg)	256	448
	H	(mm)	1302	1362	
	AUMA SAR 10.2	PN16	(kg)	233	411
		PN25/40	(kg)	260	452

Standard-flange dimensions refer to page 15.

(For version with AUMA SAR Ex other heights.)

Face-to-face dimension FTF series 1 according to DIN EN 558

Parts

Pos.	Description	Fig. 12.423 Fig. 12.463	Fig. 22.423 Fig. 22.463	Fig. 34.423 / Fig. 35.463 Fig. 34.423 / Fig. 35.463
1	Body	EN-GJL-250, EN-JL1040	EN-GJS-400-18U-LT, EN-JS1049	GP240GH+N, 1.0619+N
2	Seat ring *	X20Cr13+QT, 1.4021+QT		
3	Bottom flange	EN-GJS-400-18U-LT, EN-JS1049		GP240GH+N, 1.0619+N
4	Guide bushing	X20Cr13+QT, 1.4021+QT		
5	Gasket *	Pure graphite (CrNi laminated with graphite)		
6	Studs	25CrMo4, 1.7218		
7	Hexagon nut	C35E, 1.1181		
8	Plug *	X20Cr13+QT, 1.4021+QT		
9	Straight pin *	56Si7, 1.5026		
10	Stem *	X20Cr13+QT, 1.4021+QT		
12	Stuffing box housing	EN-GJS-400-18U-LT, EN-JS1049		GP240GH+N, 1.0619+N
13	Guide bushing	X20Cr13+QT, 1.4021+QT (hardened)		
15	Stem adapter *	X20Cr13+QT, 1.4021+QT		
16	Straight pin *	56Si7, 1.5026		
17	Packing ring *	PTFE or Pure graphite		
19	Washer *	X5CrNi18-10, 1.4301		
20	Packing box flange	EN-GJS-400-18U-LT, EN-JS1049		
21	Studs	25CrMo4, 1.7218		
22	Hexagon nut	C35E, 1.1181		
23	Adapter flange	EN-GJS-400-18U-LT, EN-JS1049		
24	Hexagon socket head screw	8.8 - A2B		
25.1	Bellows housing	EN-GJS-400-18U-LT, EN-JS1049		GP240GH+N, 1.0619+N
25.2	Mounting bonnet	EN-GJS-400-18U-LT, EN-JS1049		GP240GH+N, 1.0619+N
25.3	Stem- / Bellows unit *	X20Cr13+QT, 1.4021+QT / X6CrNiTi18-10, 1.4541		
25.5	Guide bushing	X20Cr13+QT, 1.4021+QT (hardened)		
25.6	Gasket *	Pure graphite (CrNi laminated with graphite)		
25.7	Studs	25CrMo4, 1.7218		
25.8	Hexagon nuts	C35E, 1.1181		
25.9	Straight pin	St		
25.10	Packing ring *	Pure graphite		
25.12	Washer *	X5CrNi18-10, 1.4301		
25.13	Stuffing box housing	GP240GH+N, 1.0619+N		
25.15	Packing follower *	X20Cr13+QT, 1.4021+QT		
25.16	Sleeve nut *	X8CrNiS18-9, 1.4305		
20.17	Screw joint *	X8CrNiS18-9, 1.4305		
27	Gasket *	Pure graphite (CrNi laminated with graphite)		
28	Studs	25CrMo4, 1.7218		
29	Hexagon nut	C35E, 1.1181		
30	Plug *	X20Cr13+QT, 1.4021+QT		
31	Plug *	X20Cr13+QT, 1.4021+QT		
32	Castle nut *	C35E, 1.1181		
33	Cotter pin	A4		

* Spare parts

Information / restriction of technical rules to be observed!

ARI-Valves of EN-JL1040 are not allowed to be operated in systems acc. to TRD 110.

A production allowance acc. to TRB 801 No. 45 exists (acc. to TRB 801 No. 45 EN-JL1040 is not allowed.)

The engineer, designing a system or a plant, is responsible for the selection of the correct valve.

max. permissible closing pressures for both seat positions on flow-to-open P2 = 0
 Observe restrictions by Pressure-temperature-ratings, refer to page 15.

Fig. 423

Mixing function 	DN		200		250		
	Standard Kvs-values	Seat-Ø A/B (mm)			200		250
Kvs-value				630		1000	
Travel (mm)				65		65	
Reduced Kvs-values		Seat-Ø A/B (mm)	150		200		
Kvs-value			400		630		
Travel (mm)			50		65		
Max. differential pressure drop (bar)			10	10	10	10	
Actuator ¹⁾ AUMA SAR 07.6 Output drive Form A TR 26 x 5 - LH	Closing pressure (bar)	II.	shut off	11,9	6,6	6,6	4,1
			controlling ³⁾	5,5	2,9	2,9	1,8
	Torque (Nm)			60		60	
	Operating time ²⁾ (s)			55	71	71	
Output drive (min ⁻¹)			11	11	11		
Actuator ¹⁾ AUMA SAR 10.2 Output drive Form A TR 26 x 5 - LH	Closing pressure (bar)	II.	shut off	24,8	13,9	13,9	8,8
			controlling ³⁾	11,9	6,6	6,6	4,1
	Torque (Nm)			120		120	
	Operating time ²⁾ (s)			55	71	71	
Output drive (min ⁻¹)			11	11	11		
Actuator ¹⁾ AUMA SAR 14.2 Output drive Form A TR 30 x 6 - LH	Closing pressure (bar)	II.	shut off	40	23,9	23,9	15,3
			controlling ³⁾	20	11,1	11,1	7,1
	Torque (Nm)			250		250	
	Operating time ²⁾ (s)			63	59	59	
Output drive (min ⁻¹)			8	11	11		

II. Fig. 423: PTFE- / pure graphite-packing

Diverting function 	DN		200		250		
	Standard Kvs-values	Seat-Ø A/B (mm)			150		180
Kvs-value				355		560	
Travel (mm)				50		65	
Reduced Kvs-values		Seat-Ø A/B (mm)	115		150		
Kvs-value			212		355		
Travel (mm)			50		50		
Max. differential pressure drop (bar)			10	10	10	10	
Actuator ¹⁾ AUMA SAR 07.6 Output drive Form A TR 26 x 5 - LH	Closing pressure (bar)	II.	shut off	20,5	11,9	11,9	8,2
			controlling ³⁾	9,5	5,5	5,5	3,7
	Torque (Nm)			60		60	
	Operating time ²⁾ (s)			55	71	71	
Output drive (min ⁻¹)			11	11	11		
Actuator ¹⁾ AUMA SAR 10.2 Output drive Form A TR 26 x 5 - LH	Closing pressure (bar)	II.	shut off	40	24,8	24,8	17,2
			controlling ³⁾	20,5	11,9	11,9	8,2
	Torque (Nm)			120		120	
	Operating time ²⁾ (s)			55	71	71	
Output drive (min ⁻¹)			11	11	11		
Actuator ¹⁾ AUMA SAR 14.2 Output drive Form A TR 30 x 6 - LH	Closing pressure (bar)	II.	shut off	40	40	40	29,6
			controlling ³⁾	34,2	20	20	13,8
	Torque (Nm)			250		250	
	Operating time ²⁾ (s)			63	59	59	
Output drive (min ⁻¹)			8	11	11		

II. Fig. 423: PTFE- / pure graphite-packing

¹⁾ Motor voltage: 400V 50Hz 3~
 (Other voltages on request)
 Technical data for actuator refer to price list.

²⁾ Indicated operating times with 50Hz.

³⁾ Restrictions through max. permissible torque of the actuator at controlling operation.

max. permissible closing pressures for both seat positions on flow-to-open P2 = 0
 Observe restrictions by Pressure-temperature-ratings, refer to page 15.

Fig. 463

Mixing function	DN		200		250		
		Standard Kvs-values	Seat-Ø A/B (mm)		200		250
Kvs-value				630		1000	
Travel (mm)				65		65	
Reduced Kvs-values		Seat-Ø A/B (mm)	150		200		
		Kvs-value	400		630		
		Travel (mm)	50		65		
Max. differential pressure drop (bar)			10	10	10	10	
Actuator ¹⁾ AUMA SAR 07.6 Output drive Form A TR 26 x 5 - LH	Closing pressure (bar)	III.	shut off	11,9	6,6	6,6	4,1
			controlling ³⁾	5,5	3	3	1,8
	Torque (Nm)			60		60	
	Operating time ²⁾ (s)			55	71	71	
Output drive (min ⁻¹)			11		11		
Actuator ¹⁾ AUMA SAR 10.2 Output drive Form A TR 26 x 5 - LH	Closing pressure (bar)	III.	shut off	18,4	10,2	10,2	6,5
			controlling ³⁾	11,9	6,6	6,6	4,1
	Torque (Nm)			90		90	
	Operating time ²⁾ (s)			55	71	71	
Output drive (min ⁻¹)			11	11	11		

III. Fig. 463: Bellows seal

Diverting function	DN		200		250		
		Standard Kvs-values	Seat-Ø A/B (mm)		150		180
Kvs-value				355		560	
Travel (mm)				50		65	
Reduced Kvs-values		Seat-Ø A/B (mm)	115		150		
		Kvs-value	212		355		
		Travel (mm)	50		50		
Max. differential pressure drop (bar)			10	10	10	10	
Actuator ¹⁾ AUMA SAR 07.6 Output drive Form A TR 26 x 5 - LH	Closing pressure (bar)	III.	shut off	21,1	11,9	11,9	8,2
			controlling ³⁾	10,2	5,5	5,5	3,7
	Torque (Nm)			60		60	
	Operating time ²⁾ (s)			55		55	71
Output drive (min ⁻¹)			11		11		
Actuator ¹⁾ AUMA SAR 10.2 Output drive Form A TR 26 x 5 - LH	Closing pressure (bar)	III.	shut off	32,1	18,4	18,4	12,7
			controlling ³⁾	21,1	11,9	11,9	8,2
	Torque (Nm)			90		90	
	Operating time ²⁾ (s)			55		55	71
Output drive (min ⁻¹)			11		11		

III. Fig. 463: Bellows seal

¹⁾ Motor voltage: 400V 50Hz 3~
 (Other voltages on request)
 Technical data for actuator refer to price list.

²⁾ Indicated operating times with 50Hz.

³⁾ Restrictions through max. permissible torque of the actuator at controlling operation.

Control valve in 3-way-form with pneumatic actuator DP (3-way mixing valve / 3-way diverting valve)

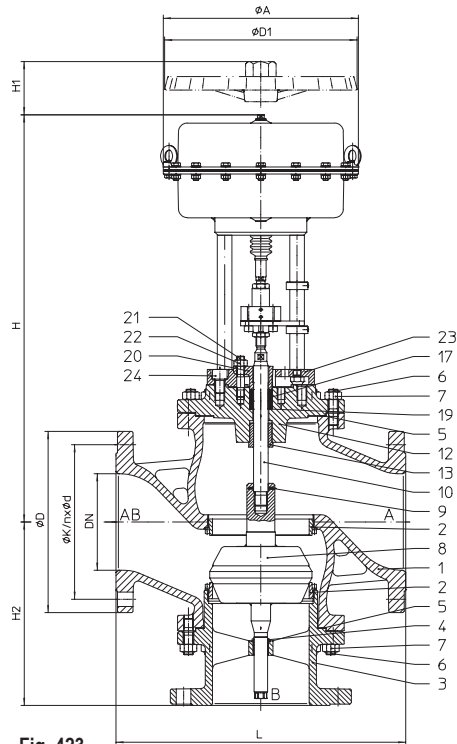

Fig. 423

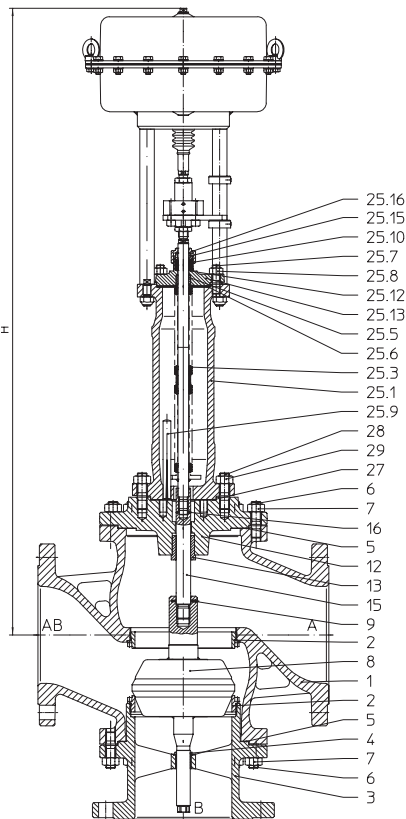
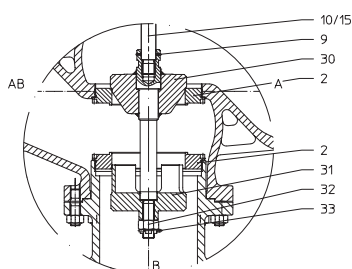

Fig. 463



Diverting construction

(Further information refer to page 16)

Figure	Nominal pressure	Material	Nominal diameter
12.423 / 12.463	PN16	EN-JL1040	DN200-250
22.423 / 22.463	PN16	EN-JS1049	DN200-250
34.423 / 34.463	PN25	1.0619+N	DN200-250
35.423 / 35.463	PN40	1.0619+N	DN200-250

Other materials and versions on request.

Stem sealing

Fig. 423: • PTFE-packing -10°C to +250°C

• Pure graphite-packing -10°C to +450°C

Fig. 463: • Stainless steel bellows seal with safety stuffing box -60°C to +450°C

Plug design

• Mixing plug: parabolic plug / parabolic plug

• Diverting plug: parabolic plug / V-port plug

Guiding

• Mixing plug: double guiding

• Diverting plug: stem and port guiding

Flow characteristic

• linear

Rangeability

• 30 : 1

Shut off class (Seat / plug leakage classes)

• Metal seat - Leakage class IV acc. to DIN EN 1349 or IEC 60534-4

Closing pressures refer to page 12.

Technical data for actuator refer to data sheet.

Selection of possible applications

Industrial installations, processing technology, plant manufacturing, etc.
(other applications on request)

Selection of possible flow media

Fig. 423: Cooling water, cooling brine, warm water, hot water, steam, gas, etc.

Fig. 463: Refrigerant, cooling water, warm water, hot water, thermal oil, steam, gas, etc.

(other flow media on request)

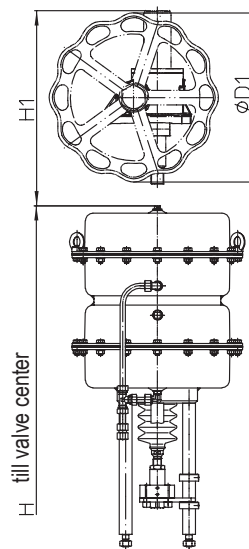

DP34T

Failure position dependent on valve duty.

Retracted stem on air failure:

- with a mixing valve port A -> AB is closed

- with a diverting valve port B -> AB is closed

Extended stem on air failure:

- with a mixing valve port B -> AB is closed

- with a diverting valve port A -> AB is closed

Top mounted handwheel

Actuator		DP34	DP34T
$\phi D1$	(mm)	397	400
H1	(mm)	458	613
Weight	(kg)	17	41

Technical data for actuator refer to data sheet DP32-34Tri.

Dimensions and weights

DN			200	250	
L	(mm)		600	730	
H2	(mm)		380	440	
Ø A	(mm)		405		
Fig. 423	DP34	H	(mm)	845	905
		PN16	(kg)	243	389
		PN25/40	(kg)	260	401
	DP34T	H	(mm)	1095	1155
		PN16	(kg)	314	460
		PN25/40	(kg)	331	472
Fig. 463	DP34	H	(mm)	1294	1354
		PN16	(kg)	246	424
		PN25/40	(kg)	273	465
	DP34T	H	(mm)	1542	1602
		PN16	(kg)	317	495
		PN25/40	(kg)	344	536

Standard-flange dimensions refer to page 15.

Face-to-face dimension FTF series 1 according to DIN EN 558

Parts

Pos.	Description	Fig. 12.423 Fig. 12.463	Fig. 22.423 Fig. 22.463	Fig. 34.423 / Fig. 35.463 Fig. 34.423 / Fig. 35.463
1	Body	EN-GJL-250, EN-JL1040	EN-GJS-400-18U-LT, EN-JS1049	GP240GH+N, 1.0619+N
2	Seat ring *	X20Cr13+QT, 1.4021+QT		
3	Bottom flange	EN-GJS-400-18U-LT, EN-JS1049		
4	Guide bushing	X20Cr13+QT, 1.4021+QT		
5	Gasket *	Pure graphite (CrNi laminated with graphite)		
6	Studs	25CrMo4, 1.7218		
7	Hexagon nut	C35E, 1.1181		
8	Plug *	X20Cr13+QT, 1.4021+QT		
9	Straight pin *	56Si7, 1.5026		
10	Stem *	X20Cr13+QT, 1.4021+QT		
12	Stuffing box housing	EN-GJS-400-18U-LT, EN-JS1049		
13	Guide bushing	X20Cr13+QT, 1.4021+QT (hardened)		
15	Stem adapter *	X20Cr13+QT, 1.4021+QT		
16	Straight pin *	56Si7, 1.5026		
17	Packing ring *	PTFE or Pure graphite		
19	Washer *	X5CrNi18-10, 1.4301		
20	Packing box flange	EN-GJS-400-18U-LT, EN-JS1049		
21	Studs	25CrMo4, 1.7218		
22	Hexagon nut	C35E, 1.1181		
23	Adapter flange	EN-GJS-400-18U-LT, EN-JS1049		
24	Hexagon socket head screw	8.8 - A2B		
25.1	Bellows housing	EN-GJS-400-18U-LT, EN-JS1049		
25.2	Mounting bonnet	EN-GJS-400-18U-LT, EN-JS1049		
25.3	Stem- / Bellows unit *	X20Cr13+QT, 1.4021+QT / X6CrNiTi18-10, 1.4541		
25.5	Guide bushing	X20Cr13+QT, 1.4021+QT (hardened)		
25.6	Gasket *	Pure graphite (CrNi laminated with graphite)		
25.7	Studs	25CrMo4, 1.7218		
25.8	Hexagon nuts	C35E, 1.1181		
25.9	Straight pin	St		
25.10	Packing ring *	Pure graphite		
25.12	Washer *	X5CrNi18-10, 1.4301		
25.13	Stuffing box housing	GP240GH+N, 1.0619+N		
25.15	Packing follower *	X20Cr13+QT, 1.4021+QT		
25.16	Sleeve nut *	X8CrNiS18-9, 1.4305		
20.17	Screw joint *	X8CrNiS18-9, 1.4305		
27	Gasket *	Pure graphite (CrNi laminated with graphite)		
28	Studs	25CrMo4, 1.7218		
29	Hexagon nut	C35E, 1.1181		
30	Plug *	X20Cr13+QT, 1.4021+QT		
31	Plug *	X20Cr13+QT, 1.4021+QT		
32	Castle nut *	C35E, 1.1181		
33	Cotter pin	A4		

* Spare parts

Information / restriction of technical rules to be observed!

ARI-Valves of EN-JL1040 are not allowed to be operated in systems acc. to TRD 110.

A production allowance acc. to TRB 801 No. 45 exists (acc. to TRB 801 No. 45 EN-JL1040 is not allowed.)

The engineer, designing a system or a plant, is responsible for the selection of the correct valve.

max. permissible closing pressures for both seat positions on flow-to-open P2 = 0
 Observe restrictions by Pressure-temperature-ratings, refer to page 15.

Spring closes port A -> AB or Spring closes port B -> AB

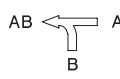
Mixing function	DN		200		250				
		Standard Kvs-values	Seat-Ø A/B (mm)		200		250		
Kvs-value				630		1000			
Travel (mm)				65		65			
Reduced Kvs-values		Seat-Ø A/B (mm)		150		200			
		Kvs-value		400		630			
		Travel (mm)		50		65			
Max. differential pressure drop (bar)			10	10	10	10			
Actuator DP34	Spring range (bar)	Air supply pressure min. (bar)	0,8-2,4	3,2	II. / III.	2,5			
			1,0-2,0	3,0	II. / III.		1,8	1,8	1,1
			1,5-3,0	4,5	II. / III.	5,6			
			2,0-4,0	6,0	II. / III.	7,8	4,3	4,3	2,6
Actuator DP34T	Spring range (bar)	Air supply pressure min. (bar)	0,4-1,2	1,6	II.	2,5 b)	1,3 b)	1,3 b)	
					III.	2,5 d)	1,3 d)	1,3 d)	
			0,8-2,4	3,2	II.	6			
					III.	6 b)			
			1,0-2,0	3,0	II.		4,3 a)	4,3 a)	2,6 a)
					III.		4,3 c)	4,3 c)	2,7 c)
1,5-3,0	4,5	II.	12,2						
		III.	12,2 a)						
2,0-4,0	6,0	II. / III.	16,6		9,2	9,2	5,8		
II. Fig. 463: PTFE- / pure graphite-packing;;			III. Fig. 463: Bellows seal						
Air supply pressure max. of pneumatic actuators DP:			max. permissible 6 bar						
Air supply pressure max. limit of control valve:			max. permissible a) 5 bar b) 4,5 bar c) 4 bar d) 3,5 bar e) 3 bar						

max. permissible closing pressures for both seat positions on flow-to-open P2 = 0

Observe restrictions by Pressure-temperature-ratings, refer to page 15.

Spring closes port AB -> A or Spring closes port AB -> B

Diverting function AB  A B	DN		200		250			
	Standard Kvs-values	Seat-Ø A/B (mm)			150		180	
Kvs-value				355		560		
Travel (mm)				50		65		
Seat-Ø A/B (mm)			115		150			
Reduced Kvs-values	Kvs-value		212		355			
	Travel (mm)		50		50			
	Max. differential pressure drop (bar)		10	10	10	10		
Actuator DP34	Spring range (bar)	Air supply pressure min. (bar)	1,6	II.	1,6			
				III.	1,6 a)			
			3,2	II. / III.	4,5	2,5	2,5	
				3,0	II. / III.			2,3
			4,5	II. / III.	9,8	5,6	5,6	
6,0	II. / III.	13,5	7,8	7,8	5,3			
Actuator DP34T	Spring range (bar)	Air supply pressure min. (bar)	1,2	II.	1,6 b)			
				III.	1,6 e)			
			1,6	II.	4,5 b)	2,5 b)	2,5 b)	1,7 b)
				III.	4,6 d)	2,5 d)	2,5 d)	1,7 d)
			3,2	II.	10,5	6	6	
				III.	10,5 b)	6,1 b)	6,1 b)	
			3,0	II.				5,3 a)
				III.				5,3 c)
4,5	II.	20,9	12,2	12,2				
	III.	21 a)	12,2 a)	12,2 a)				
6	II. / III.	28,4	16,6	16,6	11,5			

II. Fig. 423: PTFE- / pure graphite-packing;;
III. Fig. 463: Bellows seal

Air supply pressure max. of pneumatic actuators DP:

max. permissible 6 bar

Air supply pressure max. limit of control valve:

max. permissible a) 5 bar b) 4,5 bar c) 4 bar d) 3,5 bar e) 3 bar

Standard-flange dimensions

Flanges acc. to DIN EN 1092-1/-2 (Flangeholes / -thickness tol. acc. to DIN 2533/2544/2545)

DN			200	250
PN16	ØD	(mm)	340	405
	ØK	(mm)	295	355
	n x Ød	(mm)	12 x 22	12 x 26
PN25	ØD	(mm)	360	425
	ØK	(mm)	310	370
	n x Ød	(mm)	12 x 26	12 x 30
PN40	ØD	(mm)	375	450
	ØK	(mm)	320	385
	n x Ød	(mm)	12 x 30	12 x 33

Pressure-temperature-ratings acc. to DIN EN 1092-2

Material			-60°C to <-10°C*	-10°C to 120°C	150°C	200°C	250°C	300°C	350°C	400°C	450°C
EN-JL1040	16	(bar)	--	16	14,4	12,8	11,2	9,6	--	--	--
EN-JS1049	16	(bar)	on request	16	15,5	14,7	13,9	12,8	11,2	--	--

Pressure-temperature-ratings acc. to manufacturers standard

Material			-60°C to <-10°C*	-10°C to 120°C	150°C	200°C	250°C	300°C	350°C	400°C	450°C
1.0619+N	25	(bar)	18,7	25	23,9	22	20	17,2	16	14,8	8,2
1.0619+N	40	(bar)	30	40	38,1	35	32	28	25,7	23,8	13,1

Intermediate values for max. permissible operational pressures can be determined by linear interpolation of the given temperature / pressure chart.

* Valve with extended bonnet, studs and nuts made of A4-70 (at temperatures below -10°C)

Please indicate when ordering

- Figure-No.
- Nominal diameter
- Nominal pressure
- Body material
- Plug design
- Kvs-value
- Stem sealing
- Actuator
- Special design / accessories

Example:

Figure 35.423, nominal diameter DN250, nominal pressure PN40, body material 1.0619+N, mixing plug, Kvs 400, steam sealing graphite-packing, with pneumatic actuator DP34.

 Dimensions in mm
 Weights in kg
 Pressures in barü (gauge)
 1 bar $\hat{=}$ 10⁵ Pa $\hat{=}$ 0,1 MPa
 Kvs in m³/h

Stem sealing

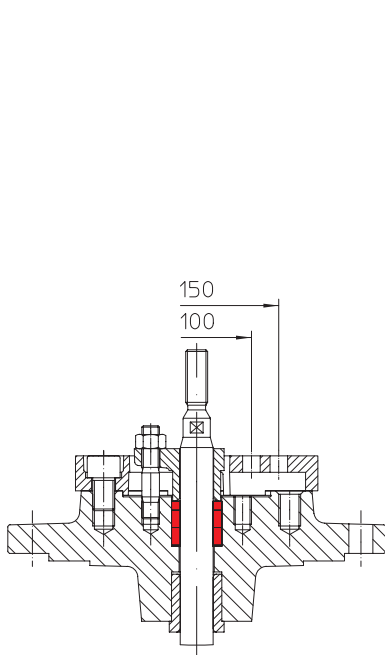

PTFE-/ Pure graphite-packing

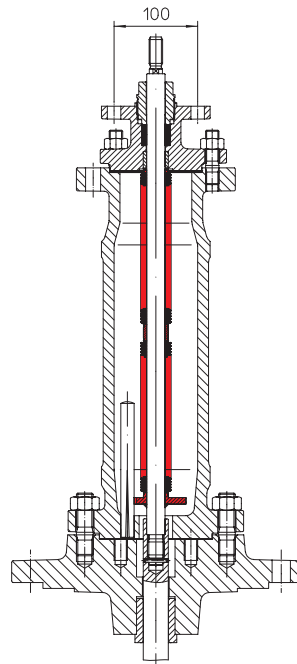

Bellows seal with safety stuffing box

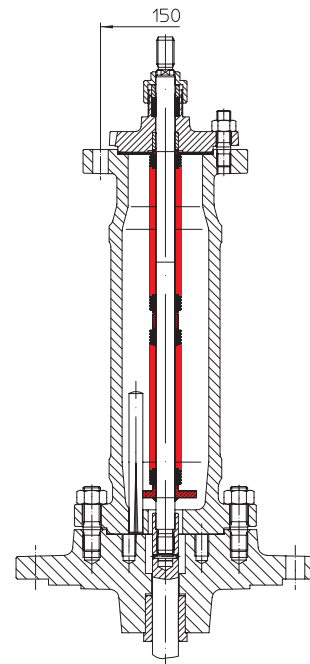

Operating mode

ARI-Control valves are suitable for use with pneumatic or electric actuators.
According to the application two different variations are possible:

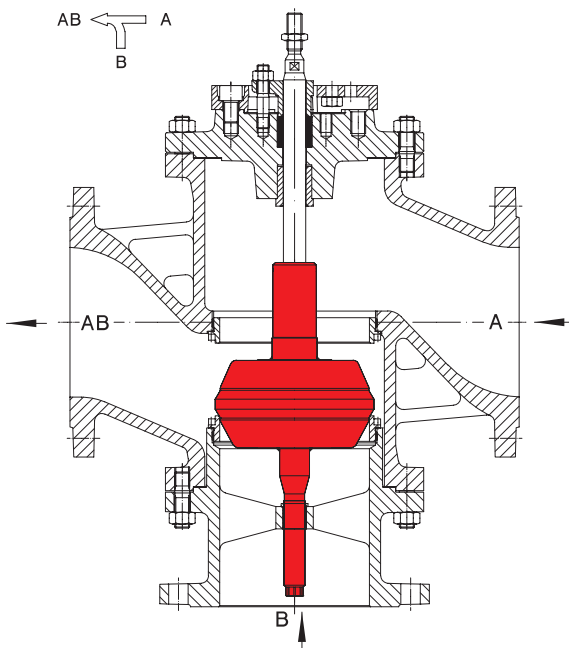

Design with mixing plug

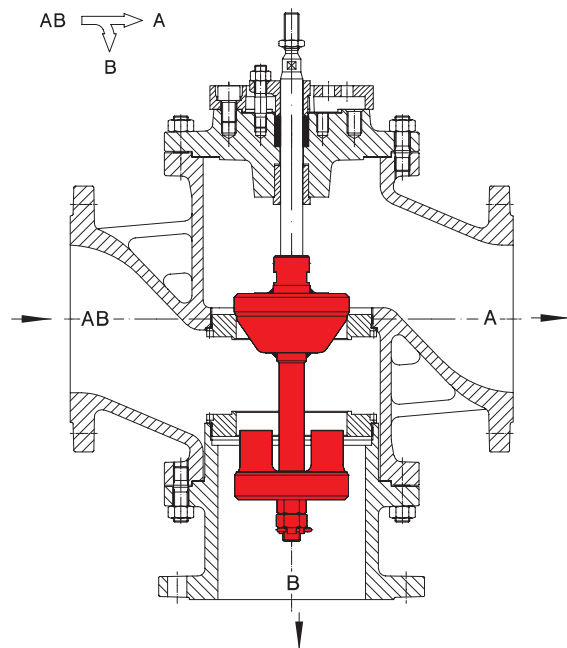

Design with diverting plug (Attention: reduced Kvs-values)

Design with mixing plug as standard.

Select when the valve is used for mixing service (2 inlets, 1 outlet).

In exceptions the design with mixing plug can also be used for diverting service (1 inlet, 2 outlets).

Only small closing pressures are possible.

Design with diverting plug will be used exclusively for diverting service.