



TYPE F46 PILOT

APPLICATION DATA

- Steam Driven Vacuum Pump Control

RATINGS (Maximum Inlet Conditions)

Construction	Pressure PSIG (bar)	Temperature °F (°C)
Cast Iron	250 (17.2) @	450 (232)
Cast Steel	600 (41.4) @	750 (400)

SPRING PRESSURE RANGES (PSIG)

30" hg-0 psi

Canadian Registration # OC 0591.9C

SIZING INFO
PAGE 124

TYPE F46 VACUUM PUMP GOVERNOR PILOT

CONTROLS to -30" Hg

- Self Contained
- Spring Operated
- Normally Closed
- ANSI/FCI 70-2 Class IV Shutoff
- Packless Construction
- Accurate to ±1 psi
- Steam Applications
- Constant Average Discharge Pressure
- Accurate Regulation Unaffected by Service Conditions
- Easy In-line Maintenance

OPTIONS

- Adjustment Indicator
- Integral Mount

TYPICAL CONFIGURATIONS

- VACUUM PUMP CONTROLTYPE EF
- VACUUM PUMP CONTROLTYPE E2F
- VACUUM PUMP CONTROLTYPE E5F

TYPE F46 VACUUM PUMP GOVERNOR PILOT

SPECIFICATION

The Pilot shall be separate from the main valve and connected to it with a male union. The Pilot shall be normally closed design with packless construction. A strainer screen shall be built into the Pilot inlet. The Pilot shall be interchangeable on all sizes of main valves. The pilot shall automatically adjust pump discharge pressures within the spring range to maintain a constant average pressure.

MATERIALS OF CONSTRUCTION

Body, Cast Iron	ASTM A126 CI B
Body, Cast Steel	1018 St. ASTM A108-79
Stem.....	303 St. St. ASTM A582 COND A
Disc	440 St. St. ASTM A276-75 COND A
Seat	420 St. Stl ASTM A276 COND A
Gasket	Non-Asbestos
Diaphragm	301 St. Stl. MIL-5-5059C
Spring	Inconel

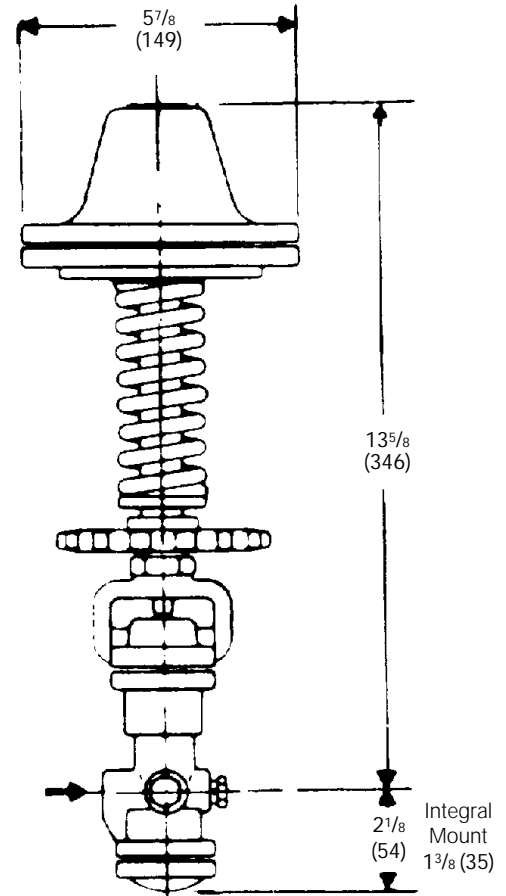

TYPE F46 VACUUM
PUMP GOVERNOR PILOT

TYPE F46 PILOT
15 LBS.
(6.8 KG)